

CANDIDATE
NAME

CENTRE
NUMBER

--	--	--	--	--

CANDIDATE
NUMBER

--	--	--	--

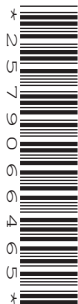

PHYSICS

5054/31

Paper 3 Practical Test

October/November 2018

2 hours

Candidates answer on the Question Paper.

Additional Materials: As listed in the Confidential Instructions.

READ THESE INSTRUCTIONS FIRST

Write your Centre number, candidate number and name on all the work you hand in.

Write in dark blue or black pen.

You may use an HB pencil for any diagrams or graphs.

Do not use staples, paper clips, glue or correction fluid.

DO NOT WRITE IN ANY BARCODES.

Answer **all** questions.

For each of the questions in Section A, you will be allowed to work with the apparatus for a maximum of 20 minutes. For the question in Section B, you will be allowed to work with the apparatus for a maximum of 1 hour.

You are expected to record all your observations as soon as these observations are made.

An account of the method of carrying out the experiments is **not** required.

Electronic calculators may be used.

You may lose marks if you do not show your working or if you do not use appropriate units.

At the end of the examination, fasten all your work securely together.

The number of marks is given in brackets [] at the end of each question or part question.

For Examiner's Use

1	
2	
3	
4	
Total	

This document consists of **13** printed pages and **3** blank pages.

Section A

Answer **all** the questions in this section.

- 1 *In this experiment, you will determine the power developed when unpeeling a piece of adhesive tape from a surface.*

You are provided with:

- exhibit A
- a loop of string attached to a short spring
- a 30 cm ruler
- a stopwatch
- a sheet of graph paper
- adhesive tape
- scissors to cut the adhesive tape.

To set up the experiment:

- look at exhibit A – **do not use, this is only for reference.**

(a) Make your own version of exhibit A:

- Cut a piece of adhesive tape 20 cm long.
- Stick 15 cm of this length of tape on to the graph paper.
- Fold the other 5 cm of tape around the end of the loop of string opposite the spring.
- Press the end of the tape around the loop to seal the loop inside, as shown in Fig. 1.1.
- Use another piece of tape to fix the left-hand edge of the paper to the bench.

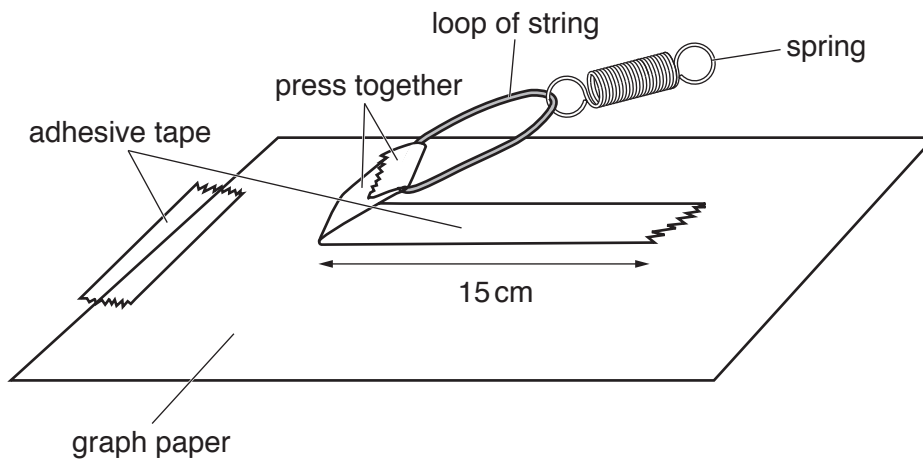

Fig. 1.1

- (b) For the spring provided, measure the unstretched length l_A of the coiled part of the spring, as shown in Fig. 1.2.

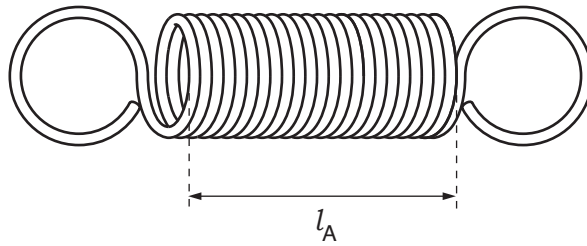

Fig. 1.2

$l_A = \dots\dots\dots$ cm [1]

- (c) (i) Pull the spring carefully and slowly to the right, as shown in Fig. 1.3.

As you pull, keep the spring very close to the bench, but not touching it.

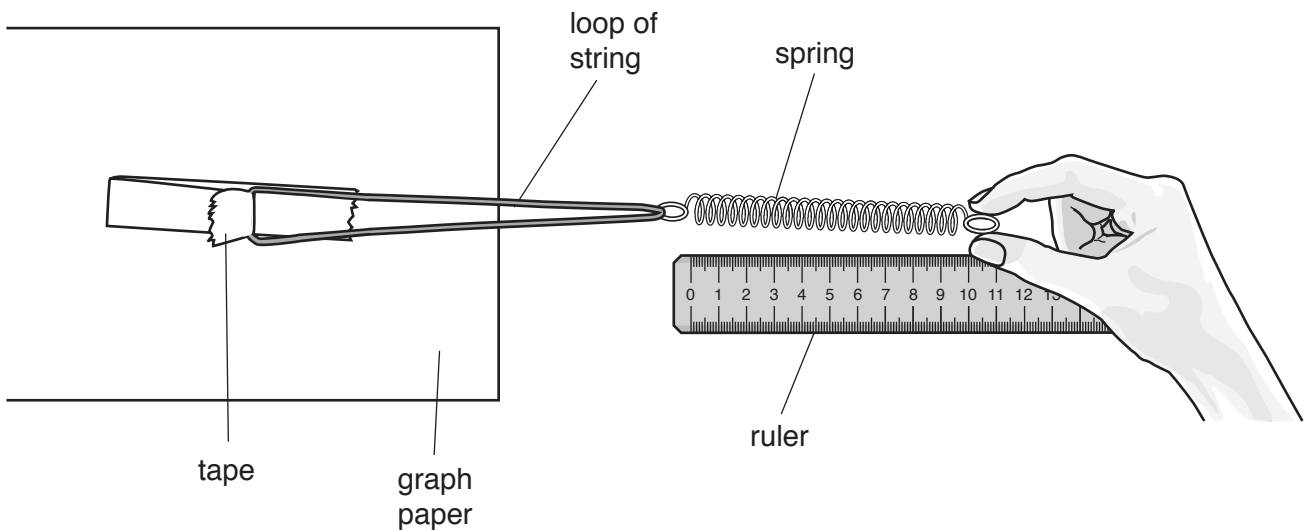

Fig. 1.3

The spring stretches. At some point the adhesive tape will **just** begin to peel away from the paper.

- (ii) Hold the spring steady in this position.

Measure the stretched length l_B of the coiled part of the spring.

$l_B = \dots\dots\dots$ cm

Use the equation $e = l_B - l_A$ to calculate the extension e of the spring.

$e = \dots\dots\dots$ cm [1]

- (iii) Use the equation $F = ke$ to calculate the force F applied by the spring, where $k = 0.25 \text{ N/cm}$.

Give the unit of your answer.

$$F = \dots\dots\dots \text{ unit } \dots\dots\dots [1]$$

- (d) Repeat c(i).

As soon as the adhesive tape begins to peel away from the paper, start the stopwatch.

Continue pulling and maintain a constant extension of the spring until 3.0 cm of the tape has been peeled away from the paper.

Stop the stopwatch.

Record the time t taken to peel 3.0 cm of the tape away from the paper.

$$t = \dots\dots\dots \text{ s } [1]$$

- (e) Use the equation $P = \frac{0.030F}{t}$ to calculate the power P developed.

$$P = \dots\dots\dots \text{ W } [1]$$

2 In this experiment, you will investigate the focal length of a lens.

You are provided with:

- a lens
- a lamp
- a stand, two bosses and two clamps
- a power supply
- a metre rule
- a sheet of graph paper.

The Supervisor has set up the apparatus, as shown in Fig. 2.1. The lens and lamp have been clamped separately to the stand.

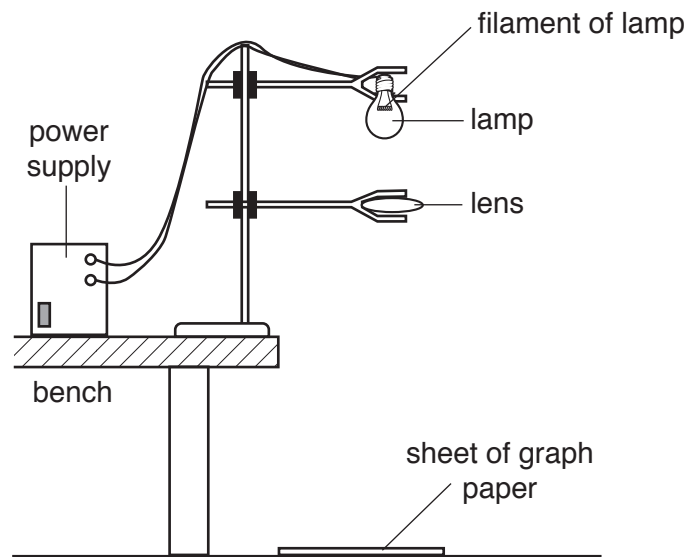

Fig. 2.1

Do not adjust the height of the lamp.

Switch on the lamp.

- (a) Adjust the height of the clamp holding the lens until a sharply focussed image of the filament of the lamp is formed on the sheet of graph paper.

You may need to adjust the position of the lens so that it is horizontal and directly beneath the lamp.

- (i) Measure the distance u from the filament of the lamp to the lens.

$u = \dots\dots\dots$ cm [1]

- (ii) Measure the distance v from the lens to the graph paper.

$v = \dots\dots\dots$ cm [1]

(iii) Describe **one** difficulty you had in measuring these distances.

.....
.....[1]

(b) Use the equation $f = \frac{uv}{u+v}$ to calculate the focal length f of the lens.

$f =$ cm [2]

3 In this experiment, you will determine the density of cooking oil.

You are provided with:

- a beaker containing cooking oil
- an empty measuring cylinder
- paper towels
- access to a balance.

(a) Determine the mass m_1 of the empty measuring cylinder.

$$m_1 = \dots\dots\dots \text{ g [1]}$$

(b) Pour 100 cm^3 of cooking oil from the beaker into the measuring cylinder.

Describe how you took an accurate reading of the volume of oil in the measuring cylinder. You may draw a diagram.

.....

.....

.....[1]

(c) (i) Determine the mass m_2 of the measuring cylinder containing 100 cm^3 of cooking oil.

$$m_2 = \dots\dots\dots \text{ g}$$

(ii) Calculate the mass m of the cooking oil.

$$m = \dots\dots\dots \text{ g [1]}$$

- (d) Use the equation $\rho = \frac{m}{V}$ to calculate the density ρ of the cooking oil, where V is the volume of the oil. Give the unit of your answer.

$\rho = \dots\dots\dots$ unit $\dots\dots\dots$ [2]

Section B

4 In this experiment, you will investigate the resistance of a thermistor.

You are provided with:

- a power supply
- a switch
- a thermistor
- a resistor
- a thermometer
- a beaker
- a supply of very hot water
- a dropping pipette
- a stirrer
- a supply of cold water.

The Supervisor has set up the circuit as shown in Fig. 4.1.

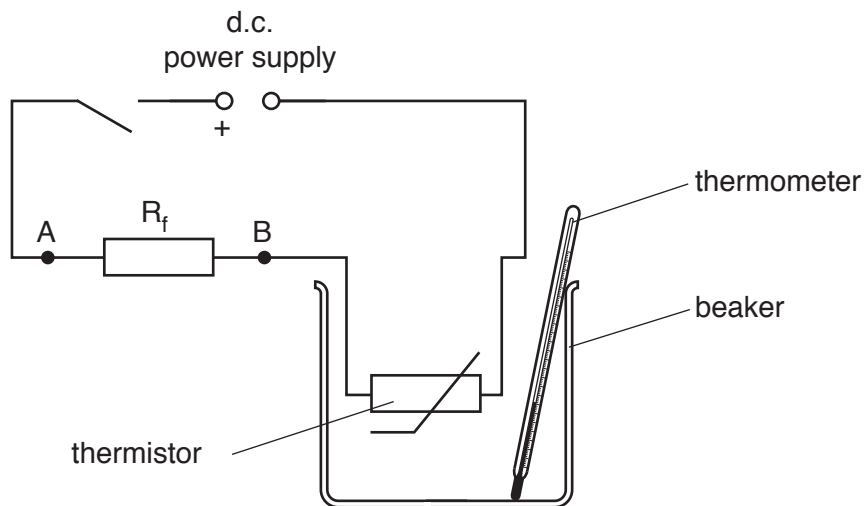

Fig. 4.1

You are also provided with:

- a voltmeter
- two connecting leads.

(a) Connect the voltmeter across the terminals of the power supply.

Ensure that the positive (+) terminal of the voltmeter is connected to the positive terminal of the power supply.

Switch on the circuit.

Record the voltmeter reading V_s .

$$V_s = \dots\dots\dots \text{ V [1]}$$

- (b) Connect the voltmeter across the fixed resistor R_f between points A and B.

Pour very hot water into the beaker until it reaches the 200 cm^3 mark.
The thermistor should be fully immersed in the water.

Put the thermometer in the beaker. Observe the temperature rise.

- (i) When the temperature reading on the thermometer stops rising, record in the first row of the results table of Fig. 4.2:

1. the temperature reading on the thermometer in the first column
2. the voltage V_{AB} across the fixed resistor R_f in the second column.

[2]

- (ii) Allow the water to cool and continue to observe the thermometer.

Take readings of the temperature and the corresponding readings of the voltage V_{AB} as the temperature decreases. You should take one voltage reading for every 3°C or 4°C decrease in temperature until the temperature reaches 50°C .

Record your readings in the table of Fig. 4.2.

The water cools slowly.

To speed up the cooling of the water, use the dropping pipette to remove some of the hot water and replace it with a similar volume of the cold water provided.
Stir the water gently when you do this.

Switch off the circuit when you have finished.

[1]

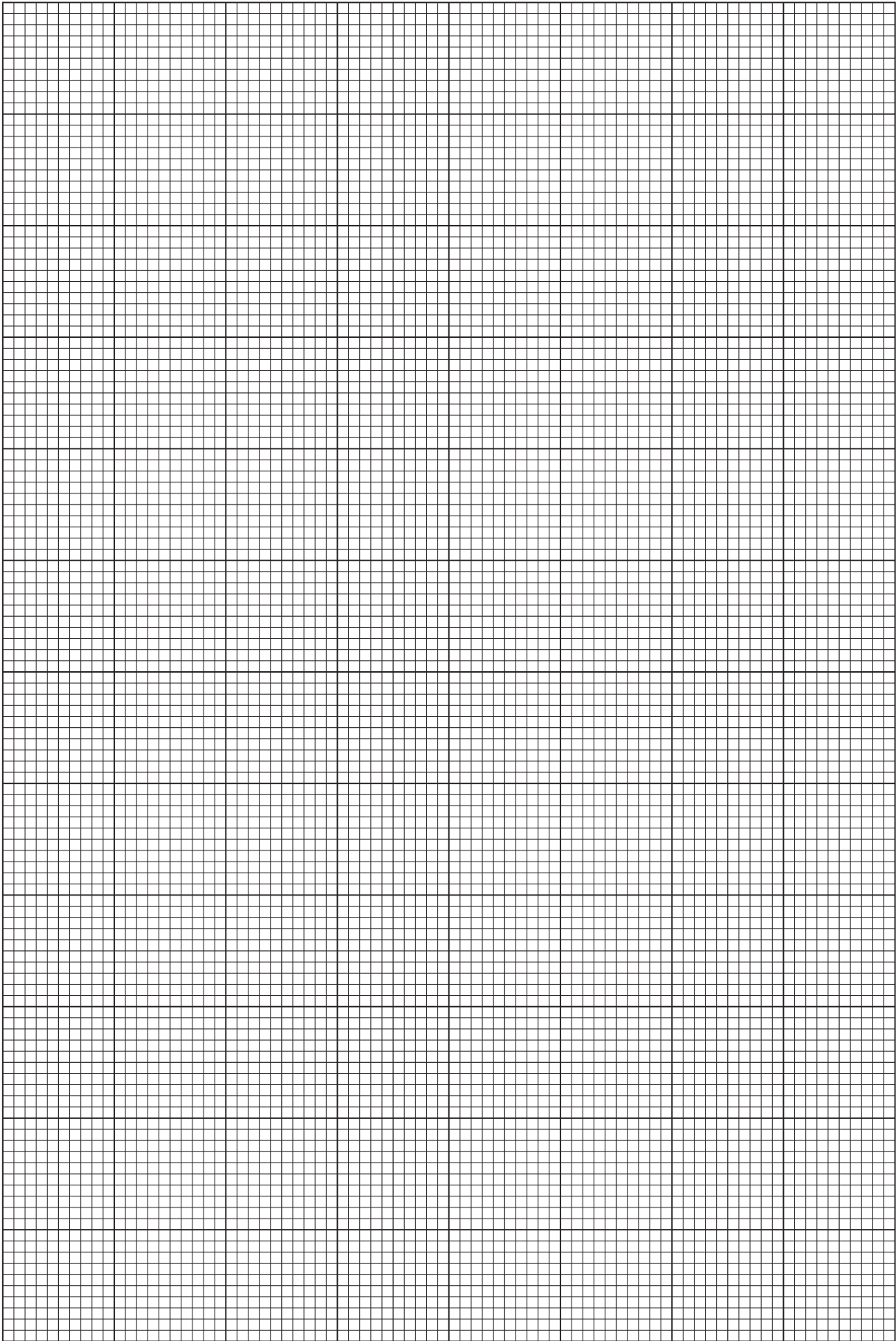

(e) Draw a tangent to the curve at a temperature of 65 °C.

Determine the gradient of your graph at this point.

gradient = [3]

BLANK PAGE

Permission to reproduce items where third-party owned material protected by copyright is included has been sought and cleared where possible. Every reasonable effort has been made by the publisher (UCLES) to trace copyright holders, but if any items requiring clearance have unwittingly been included, the publisher will be pleased to make amends at the earliest possible opportunity.

To avoid the issue of disclosure of answer-related information to candidates, all copyright acknowledgements are reproduced online in the Cambridge International Examinations Copyright Acknowledgements Booklet. This is produced for each series of examinations and is freely available to download at www.cie.org.uk after the live examination series.

Cambridge International Examinations is part of the Cambridge Assessment Group. Cambridge Assessment is the brand name of University of Cambridge Local Examinations Syndicate (UCLES), which is itself a department of the University of Cambridge.