

CANDIDATE
NAME

CENTRE
NUMBER

--	--	--	--	--

CANDIDATE
NUMBER

--	--	--	--



PHYSICS

Paper 3 Practical Test

5054/32

October/November 2019

2 hours

Candidates answer on the Question Paper.

Additional Materials: As listed in the Confidential Instructions.

READ THESE INSTRUCTIONS FIRST

Write your centre number, candidate number and name on all the work you hand in.
Write in dark blue or black pen.
You may use an HB pencil for any diagrams or graphs.
Do not use staples, paper clips, glue or correction fluid.
DO NOT WRITE IN ANY BARCODES.

Answer **all** questions.

For each of the questions in Section A, you will be allowed to work with the apparatus for a maximum of 20 minutes. For the question in Section B, you will be allowed to work with the apparatus for a maximum of 1 hour.

You are expected to record all your observations as soon as these observations are made.
An account of the method of carrying out the experiments is **not** required.

Electronic calculators may be used.

You may lose marks if you do not show your working or if you do not use appropriate units.

At the end of the examination, fasten all your work securely together.
The number of marks is given in brackets [] at the end of each question or part question.

For Examiner's Use	
1	
2	
3	
4	
Total	

This document consists of **13** printed pages and **3** blank pages.

Section A

Answer **all** the questions in this section.

1 In this experiment, you will investigate the oscillation of a mass on a spring.

You are provided with:

- 2 springs joined together end to end, attached to a piece of marked card
- a stopwatch
- 3 pieces of Blu Tack of equal mass
- a stand, boss and clamp
- a set square
- a metre rule.

Take one piece of Blu Tack and press it onto position A_1 on the card. Press the second piece onto position A_2 as shown in Fig. 1.1.

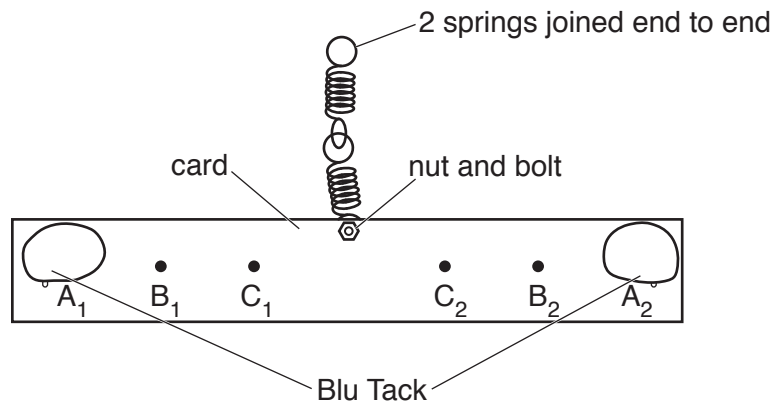

Fig. 1.1

Pass the loop of the top spring on to the clamp, and secure this loop to the clamp with the third piece of Blu Tack. Make small adjustments to the position of the Blu Tack, if necessary, to ensure that the card is horizontal as shown in Fig. 1.2.

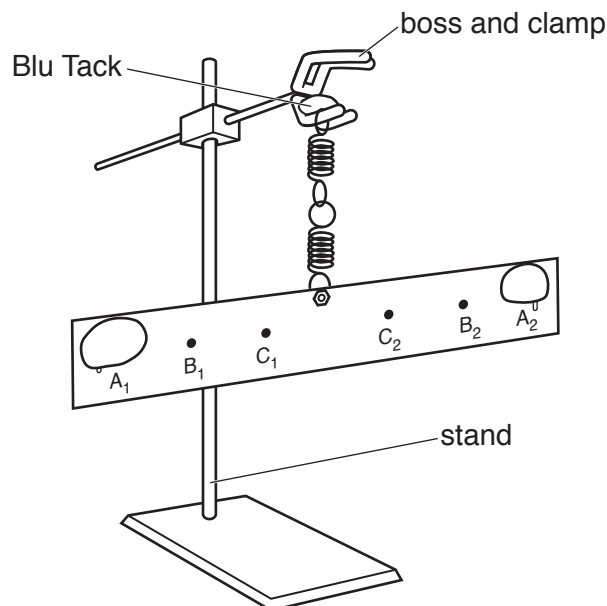

Fig. 1.2

(a) Describe how you ensure that the card is horizontal.

.....
..... [1]

(b) (i) Rotate the card by moving end A_1 away from you and end A_2 towards you. Continue to rotate until the card has moved through one complete turn and A_1 and A_2 are in their original positions.

Release the card. It will rotate in the opposite direction, stop briefly, reverse direction and stop again briefly. This is one oscillation.

Determine an accurate value of t_A , the time for one oscillation.

$t_A =$ [2]

(ii) Repeat **b(i)** to determine the time:

1. t_B for one oscillation with the Blu Tack at positions B_1 and B_2
2. t_C for one oscillation with the Blu Tack at positions C_1 and C_2 .

$t_B =$
 $t_C =$ [1]

(c) Describe the relationship between the position of the Blu Tack and the time for one oscillation.

.....
..... [1]

[Total: 5]

2 In this experiment, you will investigate the motion of a glass ball on an inclined track.

You are provided with:

- a track
- a glass ball
- a large piece of Blu Tack
- a stopwatch
- a set square
- a metre rule or 0.5 m rule

The Supervisor has set up the apparatus with the track pressed firmly into the piece of Blu Tack at one end and resting on the bench at the other end. The lower edge of the top of the track is a height h above the bench, as shown in the side view of Fig. 2.1.

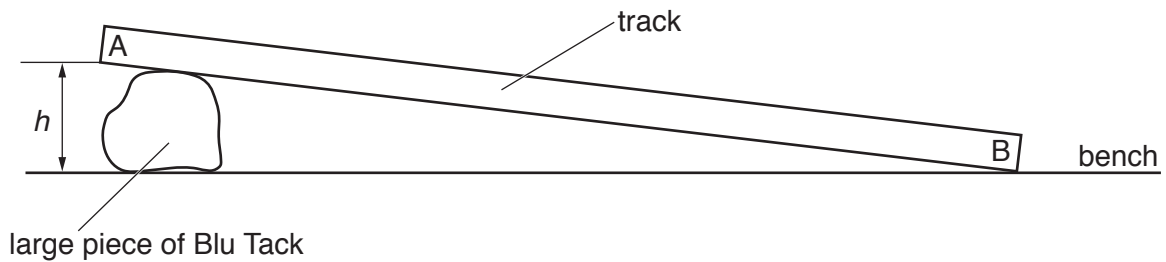

Fig. 2.1 (side view)

The track is made from two metre rules attached together with Blu Tack. The gap W_1 between the rules is wider at end A than the gap W_2 at end B.

The wider end of the track is pressed into the large piece of Blu Tack and the narrower end is resting on the bench, as shown in the view from above of Fig. 2.2.

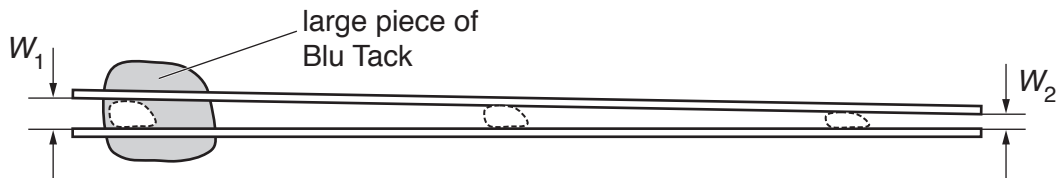

Fig. 2.2 (view from above)

(a) Use your apparatus to measure and record h , W_1 and W_2 .

$h =$

$W_1 =$

$W_2 =$

[2]

- (b) Place the glass ball on the track at end A. Release the ball. Determine the time t_1 for the ball to travel from A to B.

$t_1 = \dots\dots\dots$ [1]

- (c) Remove the track from the large piece of Blu Tack.

Place the narrow end B of the track on the large piece of Blu Tack and press firmly. Ensure that h , W_1 and W_2 are unchanged and make adjustments if necessary.

Ensure that the sides of the track are perpendicular to the bench so that the glass ball does not roll off the side of the track.

Place the glass ball at end B. Release the ball.

Determine the time t_2 for the ball to travel from B to A.

$t_2 = \dots\dots\dots$ [1]

- (d) In Fig. 2.3 the glass ball is on the track at the narrow end B.

In Fig. 2.4 the glass ball is on the track at the wide end A.

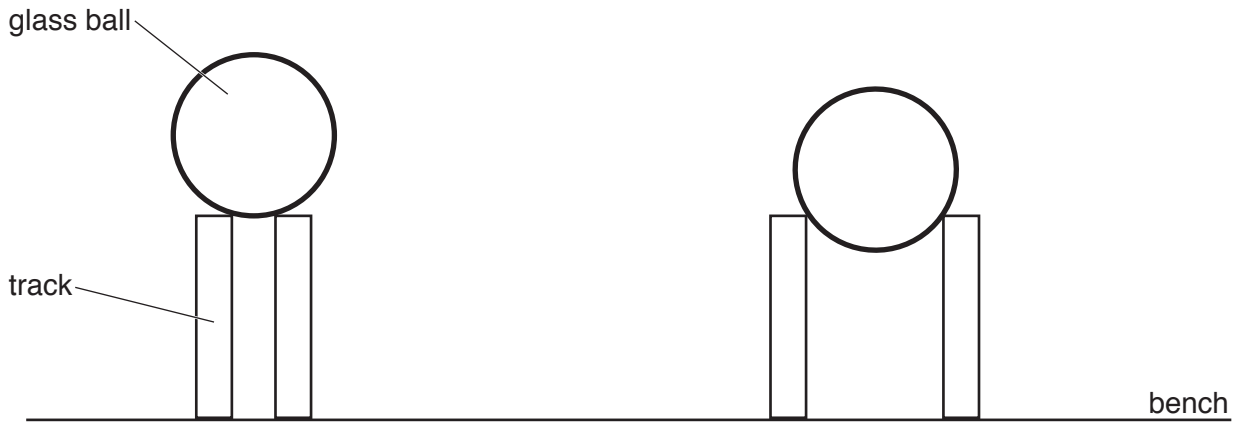

Fig. 2.3

Fig. 2.4

Suggest one reason why t_2 is different from t_1 .

.....

[1]

[Total: 5]

3 In this experiment, you will investigate the angle between rays of light.

You are provided with:

- a lamp, power supply and connecting leads
- a switch
- a protractor
- a 30 cm ruler
- a slit plate.

The Supervisor has set up the lamp as shown in Fig. 3.1.

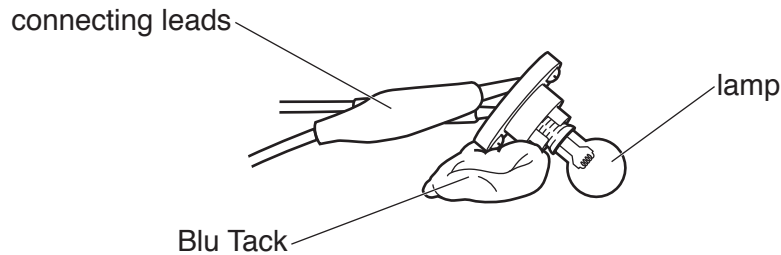

Fig. 3.1

Fig. 3.2 shows how you will set up the apparatus.

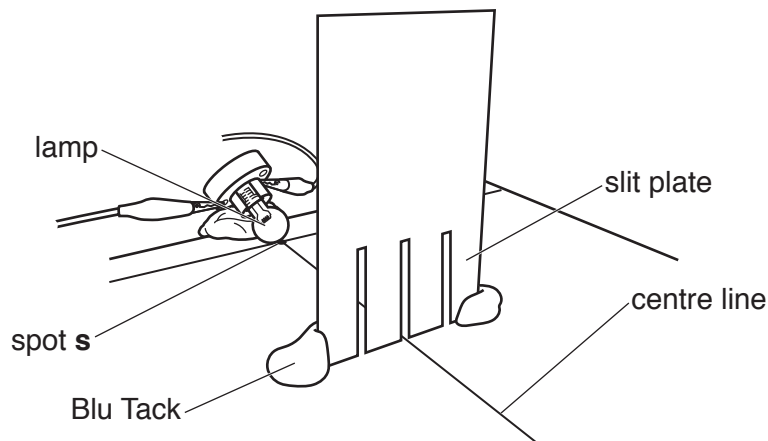

Fig. 3.2

Place the lamp so that the bulb touches the page at the spot **s** marked on Fig. 3.3 on the facing page.

Switch on the lamp.

Place the slit plate on the line AA on Fig. 3.3. Adjust the slit plate so that the ray emerging from the middle slit is aligned with the centre line marked on Fig. 3.3.

- (a)**
- (i)** On Fig. 3.3, draw lines to show the paths of the two rays diverging from the slits on each side of the middle slit. Label these lines R_1 and R_2 .
Switch the lamp off. [1]
 - (ii)** Remove the slit plate. Extend the lines R_1 and R_2 back to point **s** so that they intersect. Mark the angle subtended between R_1 and R_2 . Label this angle θ . [1]
 - (iii)** Measure the angle θ .

$\theta =$ [1]

7

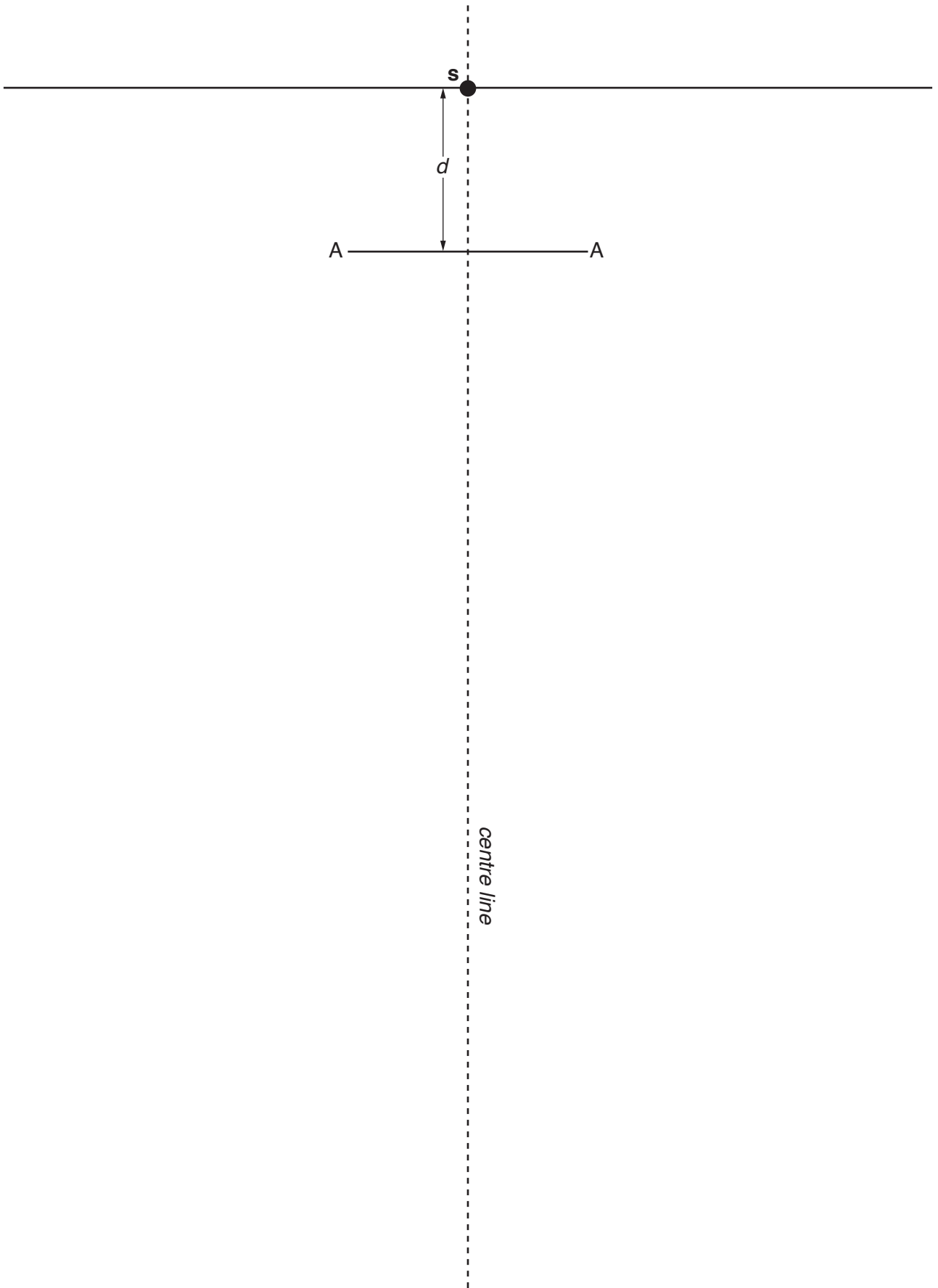

Fig. 3.3

(b) The perpendicular distance between \mathbf{s} and the line AA is d .

By making further observations, describe what happens to θ as this distance increases from d to $5d$.

.....
.....
..... [2]

[Total: 5]

SECTION B BEGINS ON PAGE 10

Section B

4 In this experiment, you will investigate the transmission of light through paper.

You are provided with:

- a lamp
- a light dependent resistor (LDR)
- a power supply
- a resistor
- a ruler with a mm scale
- a stand, boss and clamp
- a switch
- 6 sheets of white paper.

The Supervisor has set up the apparatus as shown in Fig. 4.1.

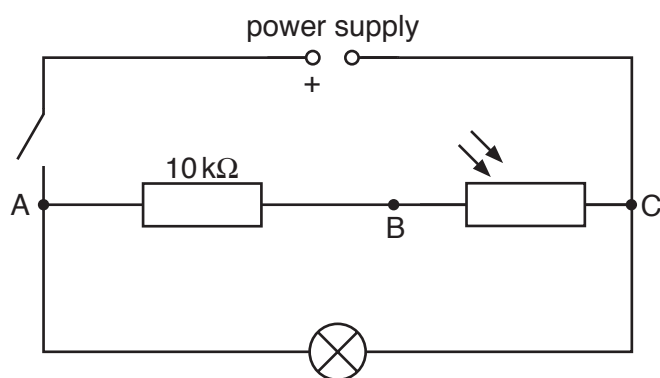

Fig. 4.1

The LDR is attached to a rod held in the jaws of a clamp, 5 mm above the lamp. Ensure that the LDR is directly above the lamp. The distance between the LDR and the lamp must **not** change throughout the investigation.

You are also provided with a voltmeter and two connecting leads.

- (a) (i) Connect the voltmeter between points A and C. Ensure that the positive (+) terminal of the voltmeter is connected to A. Close the switch. Record the voltmeter reading V_{AC} .

$$V_{AC} = \dots\dots\dots [1]$$

- (ii) Describe how you ensure that your value for V_{AC} is accurate.

.....
 [1]

- (b) (i) Disconnect the voltmeter from points A and C.
Connect the voltmeter between points A and B.
Record the voltmeter reading V_{AB} .
Open the switch.

$$V_{AB} = \dots\dots\dots [1]$$

- (ii) The current I in the resistor is given by

$$I = \frac{V_{AB}}{R}$$

where $R = 10\,000\ \Omega$.

Calculate I .

$$I = \dots\dots\dots [1]$$

- (iii) The resistance R_L of the LDR is given by:

$$R_L = \frac{V_{AC} - V_{AB}}{I}$$

Calculate R_L .

Give your answer in $k\Omega$.

$$R_L = \dots\dots\dots k\Omega [1]$$

- (c) Record your answers from (a)(i), (b)(i), (b)(ii) and (b)(iii) in the **second** row of the results table of Fig. 4.2.

Write headings in the **top** row of the results table of Fig. 4.2. [1]

- (d) V_{AC} does not change and is the value recorded in (a)(i).
Place one sheet of paper in the space between the LDR and the lamp.
Close the switch.

- (i) In the table of Fig. 4.2 record:
- the new voltmeter reading V_{AB}
 - the new current I in the resistor
 - the new resistance R_L (in $k\Omega$) of the LDR.

- (ii) Continue the investigation by increasing the number of sheets of paper in the space between the LDR and the lamp from one sheet to six sheets. Repeat (d)(i) each time.

When you have completed your measurements, open the switch.

number of sheets	V_{AC}/\dots	$\dots\dots\dots/\dots$	$\dots\dots\dots/\dots$	$\dots\dots\dots/\dots$
0				
1				
2				
3				
4				
5				
6				

Fig. 4.2

[4]

- (e) (i) On the grid on page 13, plot a graph of resistance R_L of the LDR on the y -axis against number of sheets on the x -axis.

Draw the curve of best fit.

[4]

- (ii) A student repeats the experiment using the same type of paper but with sheets of half the thickness.

On the grid, sketch the graph you expect the student to obtain.

Label this line 'half-thickness'.

[1]

[Total: 15]

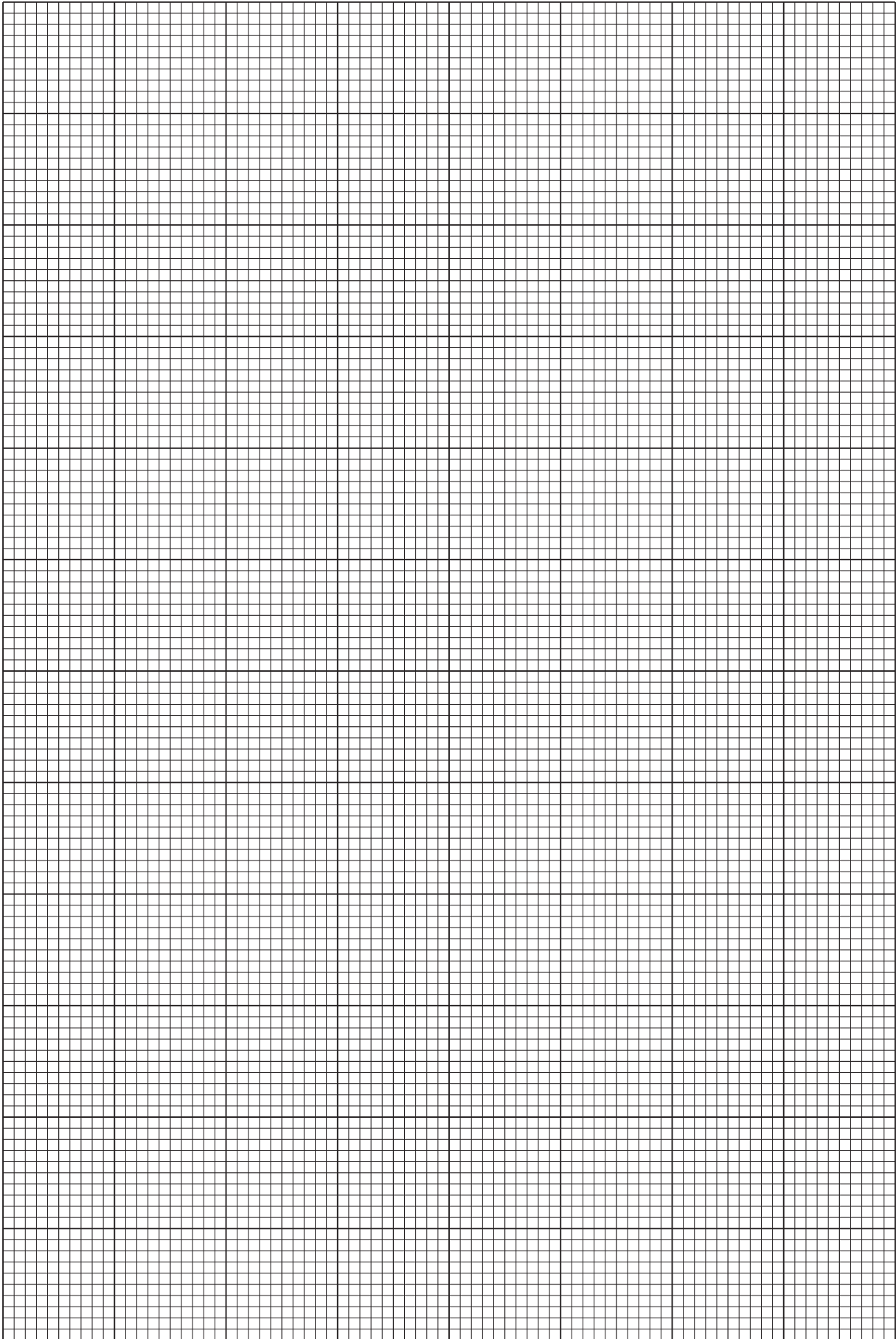

BLANK PAGE

Permission to reproduce items where third-party owned material protected by copyright is included has been sought and cleared where possible. Every reasonable effort has been made by the publisher (UCLES) to trace copyright holders, but if any items requiring clearance have unwittingly been included, the publisher will be pleased to make amends at the earliest possible opportunity.

To avoid the issue of disclosure of answer-related information to candidates, all copyright acknowledgements are reproduced online in the Cambridge Assessment International Education Copyright Acknowledgements Booklet. This is produced for each series of examinations and is freely available to download at www.cambridgeinternational.org after the live examination series.

Cambridge Assessment International Education is part of the Cambridge Assessment Group. Cambridge Assessment is the brand name of the University of Cambridge Local Examinations Syndicate (UCLES), which itself is a department of the University of Cambridge.