

CANDIDATE
NAME

CENTRE
NUMBER

--	--	--	--	--

CANDIDATE
NUMBER

--	--	--	--



CO-ORDINATED SCIENCES

0654/33

Paper 3 (Core)

October/November 2017

2 hours

Candidates answer on the Question Paper.

No Additional Materials are required.

READ THESE INSTRUCTIONS FIRST

Write your Centre number, candidate number and name on all the work you hand in.

Write in dark blue or black pen.

You may use an HB pencil for any diagrams or graphs.

Do not use staples, paper clips, glue or correction fluid.

DO NOT WRITE IN ANY BARCODES.

Answer **all** questions.

Electronic calculators may be used.

You may lose marks if you do not show your working or if you do not use appropriate units.

A copy of the Periodic Table is printed on page 28.

At the end of the examination, fasten all your work securely together.

The number of marks is given in brackets [] at the end of each question or part question.

This document consists of **26** printed pages and **2** blank pages.

1 Fig. 1.1 shows a diagram of a flower from a plant.



Fig. 1.1

(a) State the letter that represents the following parts of the flower in Fig. 1.1.

- anther
- petal
- sepal
- stigma

[4]

(b) Draw one line from each part of the flower to its correct function.

part of flower	function
anther	where ovules are produced
ovary	protects the flower when in bud
petal	produces pollen
sepal	often coloured to attract insects
stigma	where pollen is deposited

[3]

(c) Plants can undergo sexual or asexual reproduction.

State **two** ways in which sexual reproduction differs from asexual reproduction.

1

2

[2]

- 2 (a) Complete Table 2.1 by choosing numbers from the list.

Each number may be used once, more than once or not at all.

0 1 2 3 10 13 19 26 39 64

Use the information in the Periodic Table on page 28.

Table 2.1

the atomic number of iron, Fe
the group number of aluminium, Al
the number of electrons in one atom of potassium, K
the number of neutrons in one atom of hydrogen, H
the number of protons in one atom of neon, Ne

[5]

- (b) The relative mass of a proton is 1 atomic mass unit.

State the relative mass of a neutron and of an electron.

relative mass of neutron

relative mass of electron

[2]

- (c) One type of steel is a mixture containing iron and cobalt.

This steel is used to make tools.

- (i) Name the collection of metals in the Periodic Table that contains iron and cobalt.

.....[1]

- (ii) State the term used for a mixture containing metals.

.....[1]

- (iii) Suggest **one** reason why steel, rather than iron, is used to make tools.

.....

.....[1]

3 Adrenaline is a hormone released by the body in response to certain situations.

(a) Use the following words to complete the definition of a hormone.

Each word may be used once, more than once or not at all.

blood **brain** **enzymes** **gland**
liver **neurones** **organs** **receptors** **tissue**

A hormone is a chemical substance produced by a, carried by the, which alters the activity of one or more specific target and is then destroyed by the

[4]

(b) Table 3.1 contains a list of different situations.

Tick (✓) the boxes of **all** the situations that would cause a large increase in release of adrenaline.

Table 3.1

situation	
gentle walking	
bungee jumping	
drinking a glass of water	
painting a picture	
riding a roller coaster	
sitting an exam	

[3]

(c) State **two** effects of adrenaline on the body.

1

2

[2]

4 (a) A radioactive isotope of iodine is used by a doctor to examine the thyroid gland of a patient.
The patient takes a tablet containing the iodine, which is absorbed by the thyroid gland.

The iodine emits γ -rays, that are detected outside the body.

(i) Name a suitable detector for γ -rays.

..... [1]

(ii) State the meaning of the term *isotope*.

.....
..... [1]

(b) α -particles, β -particles and γ -rays are ionising.

(i) Place these three radiations in order of their ionising ability.

..... [1]
 most ionising least ionising

(ii) State **one** effect of ionising radiation on the human body.

.....
..... [1]

- (c) Fig. 4.1 shows a special thermometer used in hospitals to take the temperature of babies. The temperature reading is produced using thermal radiation from the human body. Thermal radiation is part of the electromagnetic spectrum.



Fig. 4.1

- (i) Suggest the part of the electromagnetic spectrum used by this thermometer.

.....[1]

- (ii) Fig. 4.2 shows an incomplete electromagnetic spectrum.

Add the part of the electromagnetic spectrum you have suggested in (c)(i) in the correct place in Fig. 4.2.

γ-rays		ultraviolet			microwaves	
--------	--	-------------	--	--	------------	--

Fig. 4.2

[1]

- (d) Endoscopes are used by doctors to observe inside a patient.

An endoscope uses optical fibres.

Complete Fig. 4.3 to show how a ray of light travels down an optical fibre by total internal reflection.

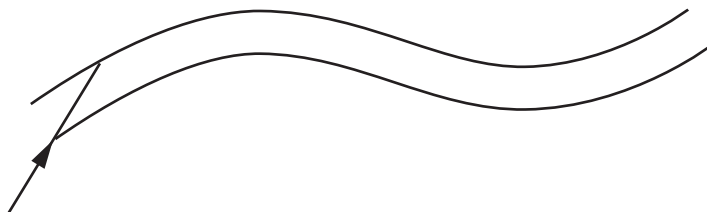

Fig. 4.3

[1]

5 Fig. 5.1 shows how the activity of three different enzymes, **A**, **B** and **C**, varies with temperature.

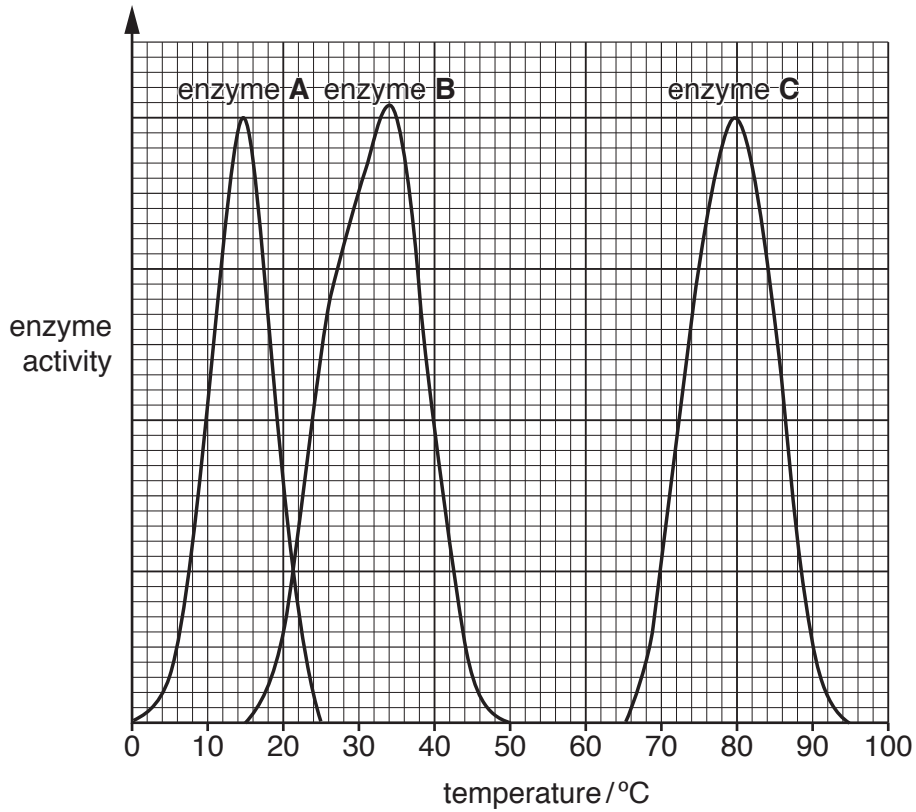

Fig. 5.1

(a) (i) State the optimum temperature for enzyme **A**.

optimum temperature°C [1]

(ii) State the range of temperatures at which enzyme **C** is active.

range is from to.....°C [1]

(b) Enzyme **B** is a protease, which is often added to biological washing powders.

It is recommended to wash clothes at a specific temperature if using a biological washing powder.

Using the information in Fig. 5.1, suggest a suitable temperature for washing clothes using a biological washing powder.

Explain your answer.

temperature°C

explanation

.....

[2]

(c) Protease breaks down proteins such as egg stains.

State the end-products of the action of protease on a protein.

.....[1]

(d) (i) Enzymes are proteins that function as biological catalysts.

State the chemical elements in an enzyme.

.....[1]

(ii) Name the chemical you would use to test for the presence of enzymes in a solution of washing powder and state the colour of a positive test.

chemical

colour of positive test

[2]

6 (a) When lithium reacts with water, a gas is produced.

(i) Name the gas that is produced in this reaction.

.....[1]

(ii) Describe a test and the result for the gas you have named in (a)(i).

test

result

[2]

(iii) Describe **one** difference between the reaction of lithium with water and the reaction of potassium with water.

.....

.....[1]

(b) The reactive non-metals in Group VII of the Periodic Table are called the halogens.

Chlorine, bromine and iodine are three of the halogens.

Fig. 6.1 shows two of these halogens, labelled X and Y, at room temperature.

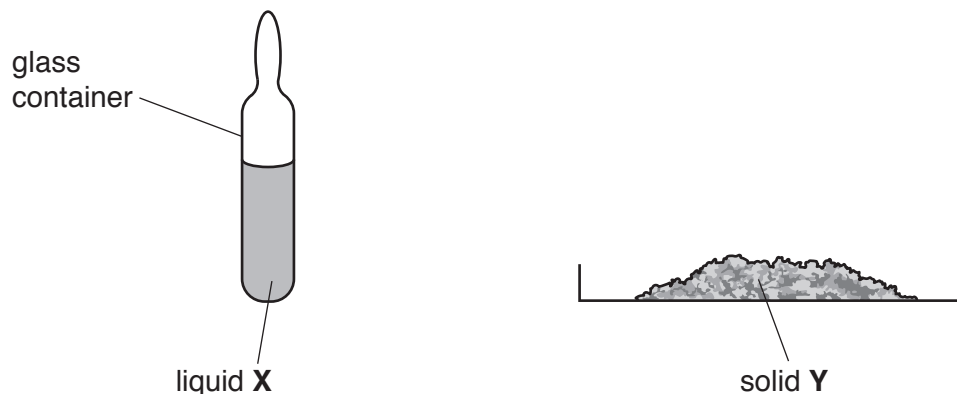

Fig. 6.1

(i) Describe the trend in melting point of the halogens down Group VII.

.....[1]

(ii) Name halogens X and Y.

X

Y

[1]

(c) When sodium reacts with chlorine, a flame is seen.

Sodium chloride is formed.

(i) State whether the reaction is endothermic or exothermic.

Explain your answer.

reaction is

explanation

..... [1]

(ii) Sodium chloride is an ionic compound.

Describe what happens to sodium atoms and to chlorine atoms when sodium and chlorine react to form sodium chloride.

Use ideas about charged particles in your answer.

.....
.....
.....
.....
.....
.....
..... [3]

(iii) Group VIII of the Periodic Table contains the noble gases.

State **and** explain what change, if any, is seen when sodium is added to argon.

change

explanation

..... [1]

7 (a) Name the electromagnetic wave used in mobile (cell) phone communication.
[1]

(b) Fig. 7.1 shows a mobile phone being charged.

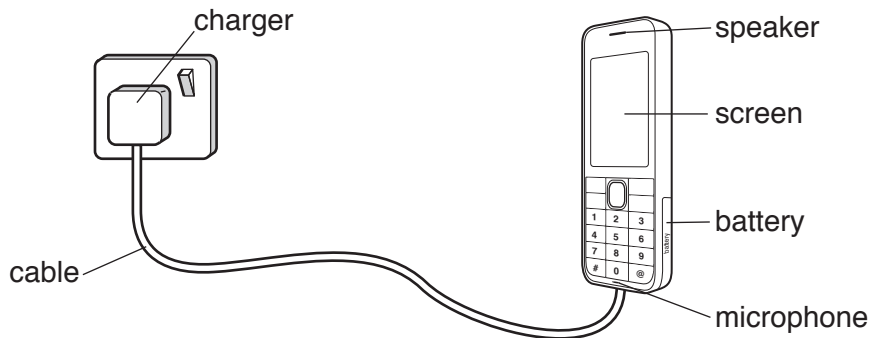

Fig. 7.1

Some parts of the mobile phone have been labelled.

Name the part of the mobile phone that transfers

- (i) electrical energy into sound energy,[1]
- (ii) electrical energy into stored chemical energy.[1]

(c) A charger for a mobile phone is marked as shown in Fig. 7.2.

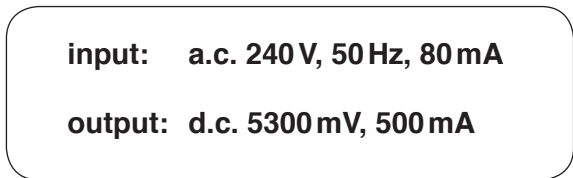

Fig. 7.2

- (i) State the physical quantity that has the unit mV.
[1]
- (ii) State the physical quantity that has the unit Hz.
[1]

(d) The ring tone on a mobile phone can be changed.

Fig. 7.3 shows the sound trace made by four sound waves on an oscilloscope screen.

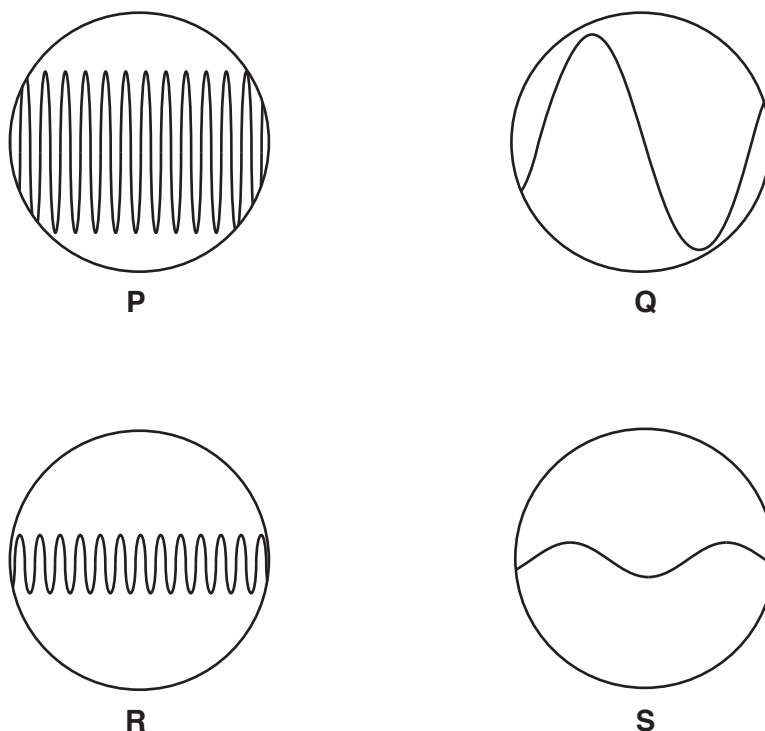

Fig. 7.3

State the letter that shows a sound trace from a ring tone which would be a

loud sound with a high pitch,

loud sound with a low pitch.

[1]

(e) The sound waves produced by the speaker of the mobile phone are longitudinal waves. The visible light waves emitted from the screen of the mobile phone are transverse waves.

Describe the difference between longitudinal wave motion and transverse wave motion.

.....

 [1]

(f) A student wants to find the work done when she lifts her mobile phone vertically from her desk to her ear.

Name the **two** quantities that the student needs to measure to determine the work done.

..... and [2]

- 8 (a) Fig. 8.1 shows pH meters being used to measure the pH of dilute sodium hydroxide solution and dilute sulfuric acid.

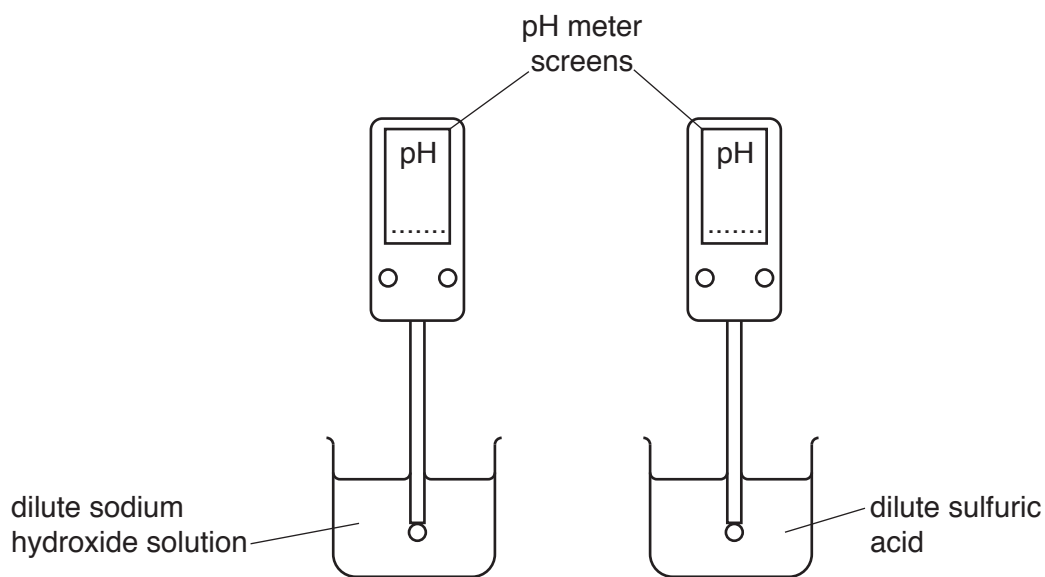
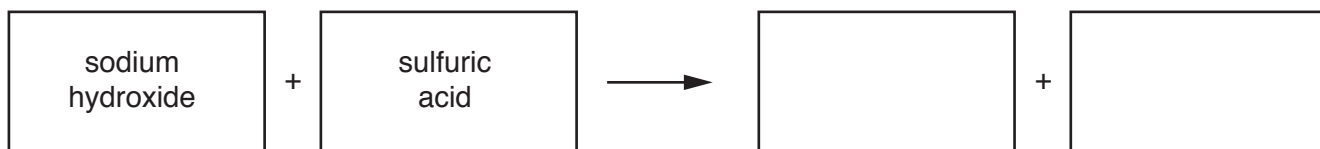

Fig. 8.1

- (i) Write suitable values of pH on the pH meter screens in Fig. 8.1 for dilute sodium hydroxide solution and dilute sulfuric acid. [1]
- (ii) Complete the **word** equation for the reaction between dilute sodium hydroxide solution and dilute sulfuric acid.



[2]

- (iii) Many colourless liquids, including water, have a pH of 7.

Describe a chemical test for water.

test

.....

result

[2]

(b) Lime is produced from calcium carbonate in an industrial process.

(i) State the chemical name for lime.

.....[1]

(ii) Name the other substance formed in this process.

.....[1]

(iii) In this process, heat is used to change a substance into simpler ones.

Name this type of chemical reaction.

.....[1]

(iv) State **and** explain a use of lime.

.....
.....
.....[2]

9 (a) Fig. 9.1 shows the distance-time graph for a bus travelling through part of a town.

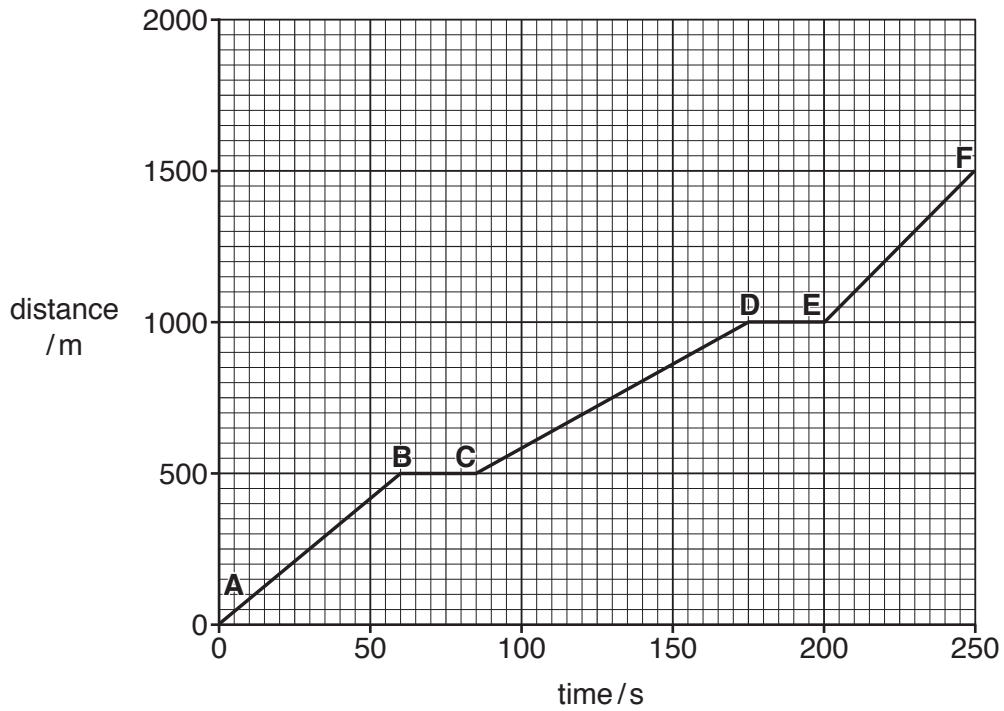

Fig. 9.1

(i) Find the total distance travelled by the bus over 250 seconds.

.....m [1]

(ii) Use the graph to calculate the maximum speed of the bus.

Show your working.

maximum speed = m/s [3]

(b) Fig. 9.2 shows the forces acting on the bus when the bus is travelling at constant speed.

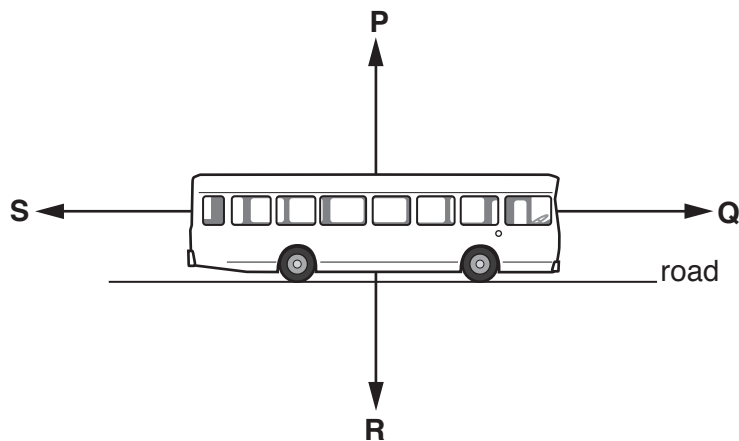

Fig. 9.2

Four forces, **P**, **Q**, **R** and **S**, are shown.

(i) State which force from **P**, **Q**, **R** and **S** is the driving force.

..... [1]

(ii) State which force from **P**, **Q**, **R** and **S** is the weight of the bus.

..... [1]

(iii) Compare the magnitude and direction of forces **Q** and **S** when the bus is travelling at constant speed.

.....

 [2]

(c) The bus has four wheels. Each wheel has a tyre inflated with air.

(i) Describe how the air molecules in a tyre exert a pressure on the wall of the tyre.

.....

 [2]

- (ii) After the journey, the tyres are hot. This means that the force of the air on the tyre wall has increased.

Explain, in terms of moving molecules, why the force of the air on the tyre wall increases when the temperature increases.

.....

.....

.....

.....

.....

.....[2]

- (d) The bus has two headlights, L_1 and L_2 . The lamp inside headlight L_1 is connected in parallel with the lamp inside headlight L_2 across a 12V battery.

The resistance of each lamp is 4.0Ω .

Fig. 9.3 shows the circuit diagram for this arrangement.

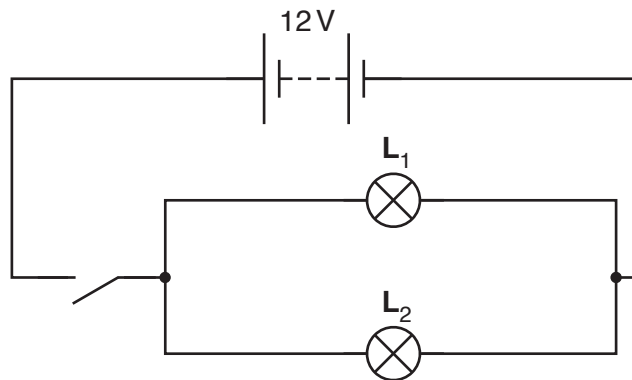

Fig. 9.3

- (i) Calculate the current passing through each lamp when the switch is closed.

State the formula you use and show your working.

formula

working

current = A [2]

(ii) The combined resistance of the two lamps connected in parallel is one of the following values.

- 2.0 Ω 4.0 Ω 8.0 Ω 16.0 Ω

State the correct value for the combined resistance.

Explain your answer.

combined resistance = Ω

because

.....

[2]

(e) Some of the bodywork on the bus is made from iron. Other parts are made from steel.

Both iron and steel are magnetic.

Describe **one** difference between the magnetic properties of iron and the magnetic properties of steel.

.....

.....[1]

10 Fig. 10.1 is a drawing of a cross-section of a leaf from a plant.

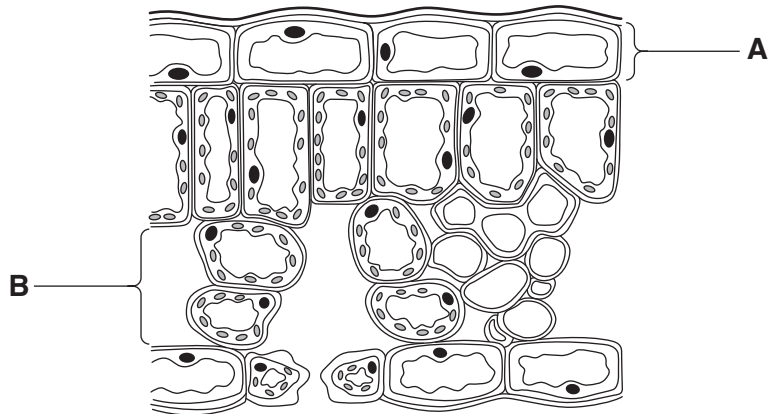

Fig. 10.1

(a) (i) Name the tissues labelled **A** and **B** in Fig. 10.1.

A

B

[2]

(ii) Add an arrow to Fig. 10.1 to show where carbon dioxide enters the leaf.

[1]

(iii) Name the process by which carbon dioxide enters the leaf.

.....[1]

(b) (i) The palisade cells between tissues **A** and **B** have the largest concentration of chloroplasts.

Suggest **and** explain why this is an advantage for the plant.

.....

[2]

(ii) State **one** similarity in structure between a palisade cell and an animal cell.

.....
[1]

11 Respiration is one of the characteristics of living things that takes place in all living cells.

(a) Complete the **word** equation for respiration.

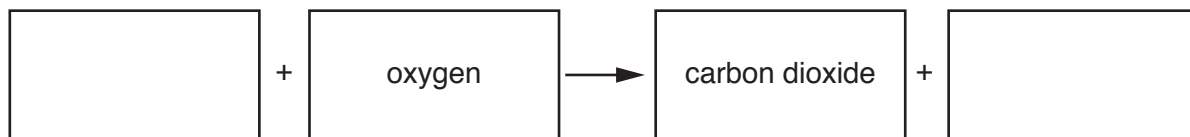

[1]

(b) Exercise increases the rate of respiration in the muscle cells.

Some energy is released as heat, which increases the body temperature.

(i) State **two** other uses of energy released by respiration in the body.

1

2 [2]

(ii) State **two** responses by the skin to increasing body temperature.

1

2 [2]

(c) A student measures their body temperature at rest and immediately after exercise.

Table 11.1 shows their results.

Table 11.1

body temperature at rest / °C	body temperature after exercise / °C
36.5	37.6

Calculate the percentage increase in their temperature values in Table 11.1.

Show your working.

.....% [2]

12 Coal, natural gas and biogas are all fuels that provide useful energy.

Natural gas and biogas both contain methane.

(a) (i) State the chemical formula of methane.

.....[1]

(ii) State **and** explain what change, if any, is seen when methane is bubbled through aqueous bromine.

change

explanation

.....[1]

(b) Natural gas is a fossil fuel.

Biogas is a fuel produced by the decomposition of animal and plant waste.

Fig. 12.1 shows the composition of natural gas and of biogas.

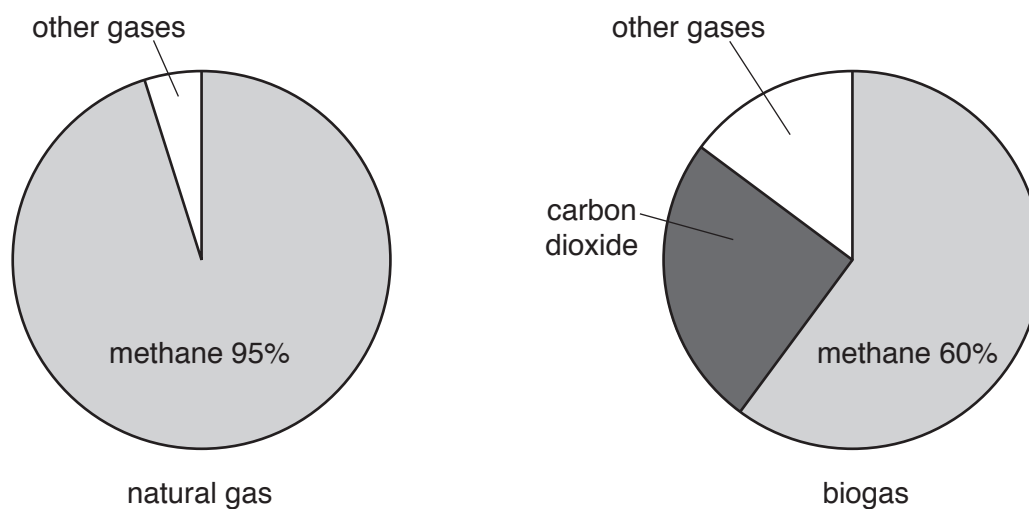

Fig. 12.1

(i) Suggest how a sample of biogas can be tested to show that it contains carbon dioxide.

test

result

[2]

(ii) Suggest why natural gas is described as a *fossil* fuel.

.....
[1]

(iii) When methane burns, the energy stored is converted into thermal energy.

State the type of energy that is stored in fuels such as methane.

.....[1]

(iv) Suggest why biogas releases less thermal energy than the same amount of natural gas.

.....

.....[1]

(c) (i) Name a sulfur compound that is produced when coal burns.

.....[1]

(ii) State **one** harmful effect on the environment of the compound named in (c)(i).

.....

.....[1]

- 13 (a) (i) An information booklet about a cooker states that the weight of the cooker is 40 kg.
Explain why this statement is incorrect.

.....
[1]

- (ii) The booklet also states that the cooker has a high energy efficiency rating.
Explain what is meant by the term *efficiency*.

.....
[1]

- (b) Some water is heated in a beaker.

Fig. 13.1 shows a graph of the temperature of the water as it is being heated in the beaker.

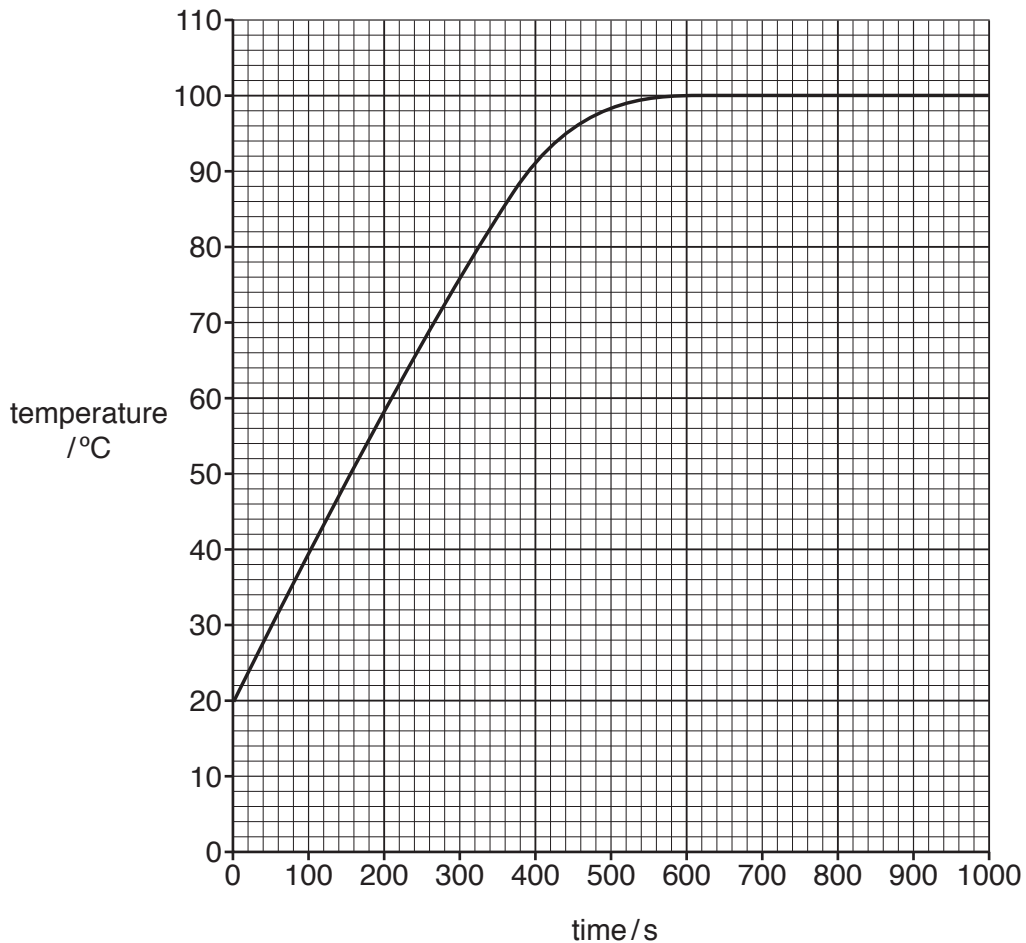

Fig. 13.1

(i) Explain why the graph shows that the water boils at 100 °C.

.....
.....
.....[1]

(ii) State the temperature rise in the first 600 seconds.

..... [1]

(iii) Complete the sentences using words from the list.

Each word may be used once, more than once or not at all.

- boiling** **bottom** **distillation** **evaporation** **faster**
slower **smaller** **steam** **surface**

As the water in the beaker is being heated, some water evaporates. This process is called This happens when water molecules escape from the of the water.

[3]

