

UNIVERSITY OF CAMBRIDGE INTERNATIONAL EXAMINATIONS
General Certificate of Education Ordinary Level

BIOLOGY

5090/01

Paper 1 Multiple Choice

May/June 2004

1 hour

Additional Materials: Multiple Choice Answer Sheet
Soft clean eraser
Soft pencil (type B or HB is recommended)

READ THESE INSTRUCTIONS FIRST

Write in soft pencil.

Do not use staples, paper clips, highlighters, glue or correction fluid.

Write your name, Centre number and candidate number on the answer sheet in the spaces provided unless this has been done for you.

There are **forty** questions on this paper. Answer **all** questions. For each question there are four possible answers **A, B, C, and D**.

Choose the **one** you consider correct and record your choice in **soft pencil** on the separate answer sheet.

Read the instructions on the Answer Sheet very carefully.

Each correct answer will score one mark. A mark will not be deducted for a wrong answer.

Any rough working should be done in this booklet.

This document consists of **17** printed pages and **3** blank pages.



1 The diagram shows the female reproductive system.

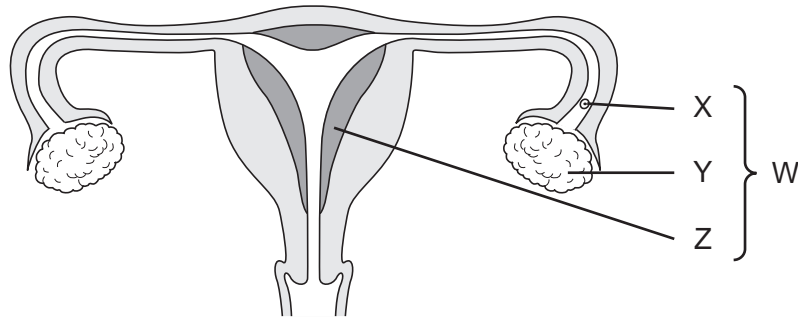

Which level of organisation are the structures W, X, Y and Z?

	cell	tissue	organ	organ system
A	W	Y	X	Z
B	X	Z	Y	W
C	Y	X	Z	W
D	Z	W	Y	X

2 Which is an example of active transport?

- A** movement of glucose into the cells of the villi
- B** movement of glucose molecules down a concentration gradient
- C** movement of ions in blood plasma
- D** movement of water in the transpiration stream

- 3 Similar shaped pieces of potato are placed in sucrose solutions of different concentrations. After three hours, the mass of each potato piece is measured.

Which graph shows the results of this experiment?

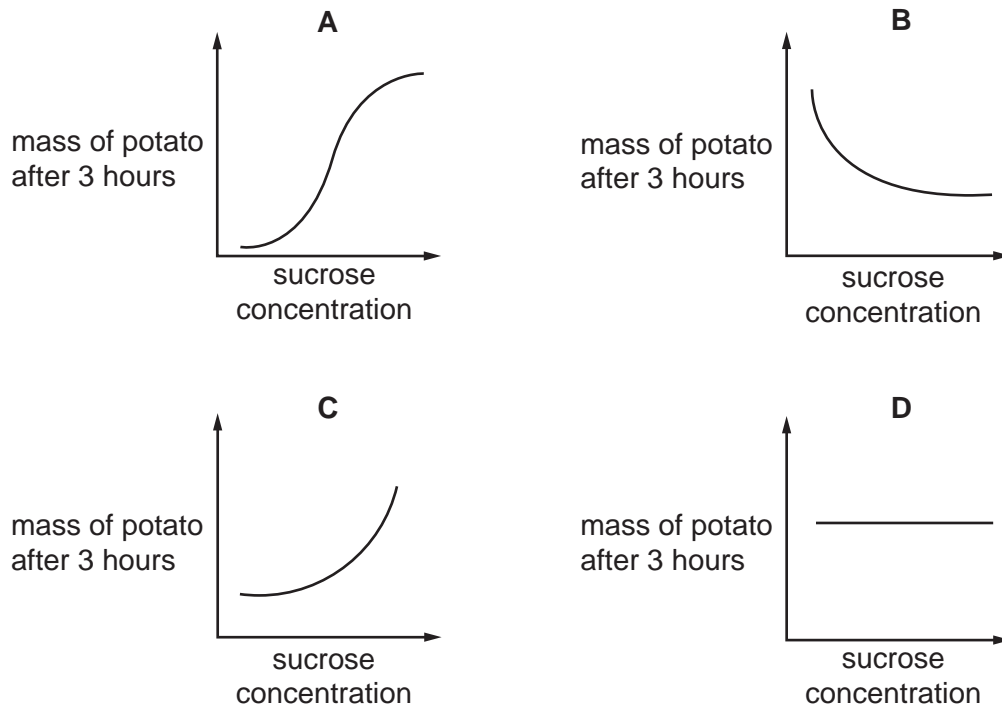

- 4 A dish is filled with agar jelly containing starch. Four holes are cut in the jelly and each hole is filled with the different substances shown.

Which hole will be surrounded by the largest area without starch after 30 minutes?

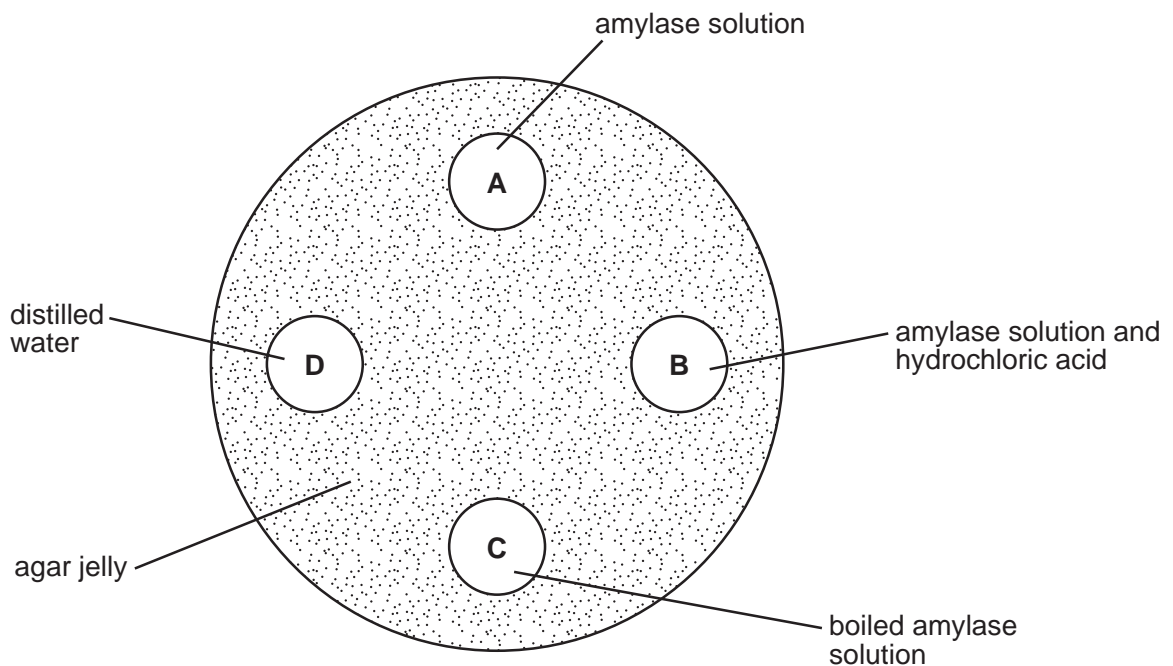

- 5 The graph shows the amount of oxygen produced by a green plant during a 24-hour period.
Which letter represents midnight?

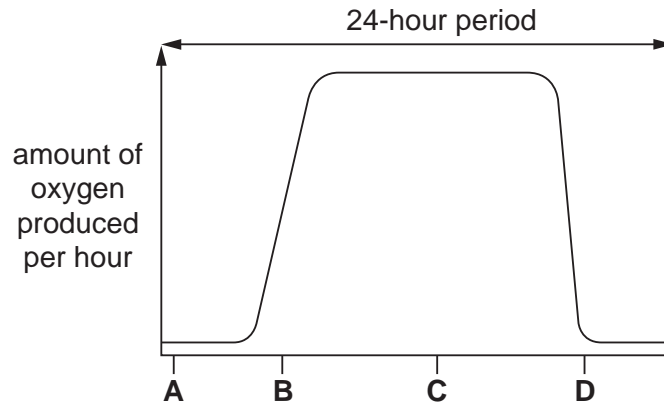

- 6 Which graph shows the effect of temperature on the rate of photosynthesis?

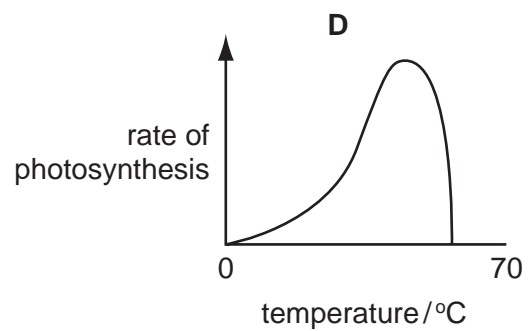
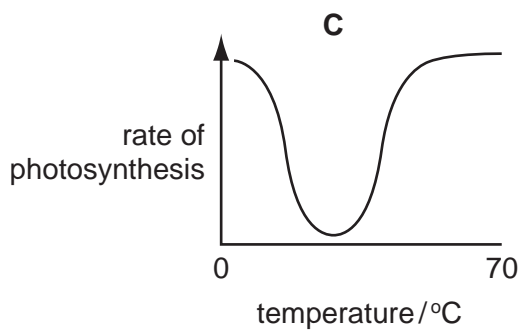
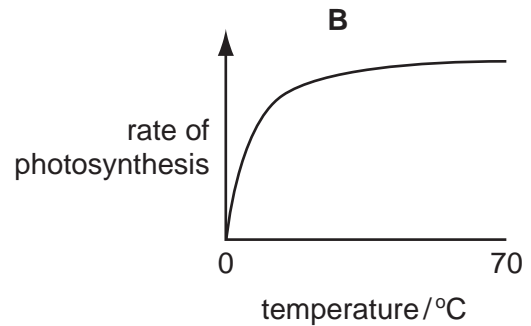
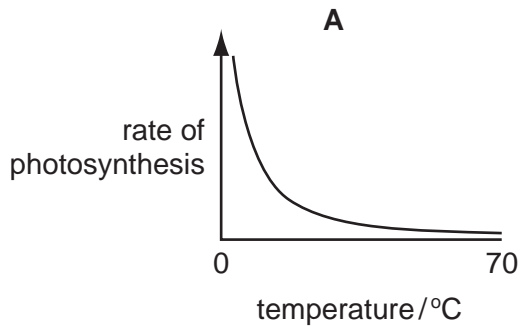

- 7 A plant is kept in the dark for two days. A leaf is used in an experiment to investigate the effect of two factors on photosynthesis, as shown in the diagram.

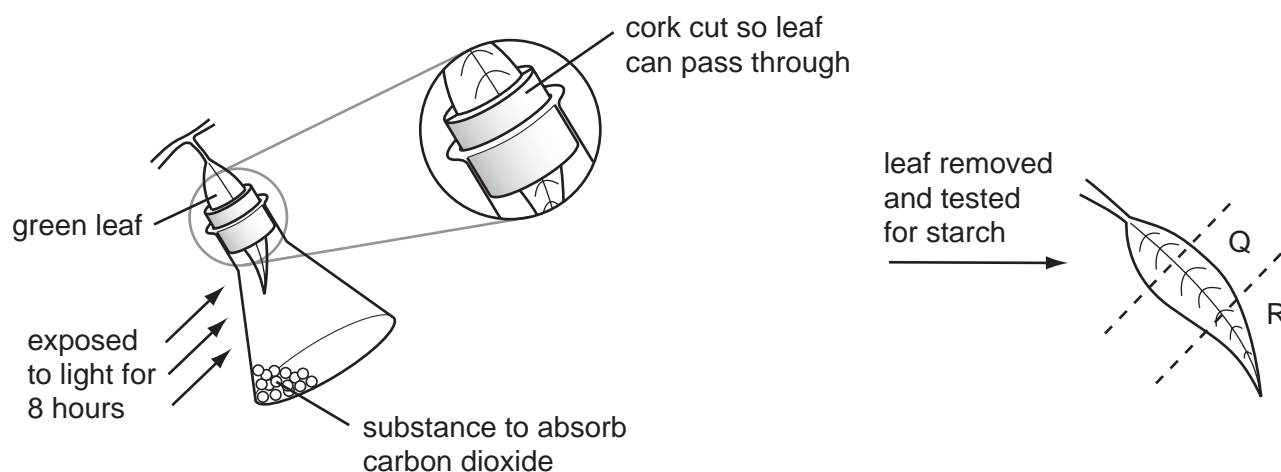

What are the colours of Q and R, when the leaf is tested for starch, using iodine solution?

	Q	R
A	blue/black	brown
B	brown	brown
C	blue/black	blue/black
D	brown	blue/black

- 8 Two samples of food are tested. The results are shown in the table.

	test used		
	iodine solution	Benedict's test	biuret test
sample 1	brown	orange	blue
sample 2	blue/black	blue	violet

What do these results show?

- A** Sample 1 contains starch and sugars.
B Sample 1 contains starch only.
C Sample 2 contains starch and protein.
D Sample 2 contains protein only.

9 The pH in the mouth decreases after eating.

Which statement explains the decrease in pH?

- A Bacteria release acids when respiring food substances.
- B Enzymes in saliva release acids during digestion.
- C Food substances become alkaline when chewed.
- D Salivary glands release an alkaline solution.

10 Large, insoluble molecules have to be digested before they can be

- A absorbed.
- B assimilated.
- C egested.
- D ingested.

11 When a leafy shoot is placed in a solution of dye, which part becomes most heavily stained?

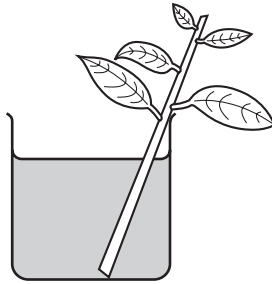

- A guard cells in the leaves
- B palisade cells in the leaves
- C phloem cells in the stem
- D xylem vessels in the stem

12 The diagrams show transverse sections from the root and the stem of a plant.

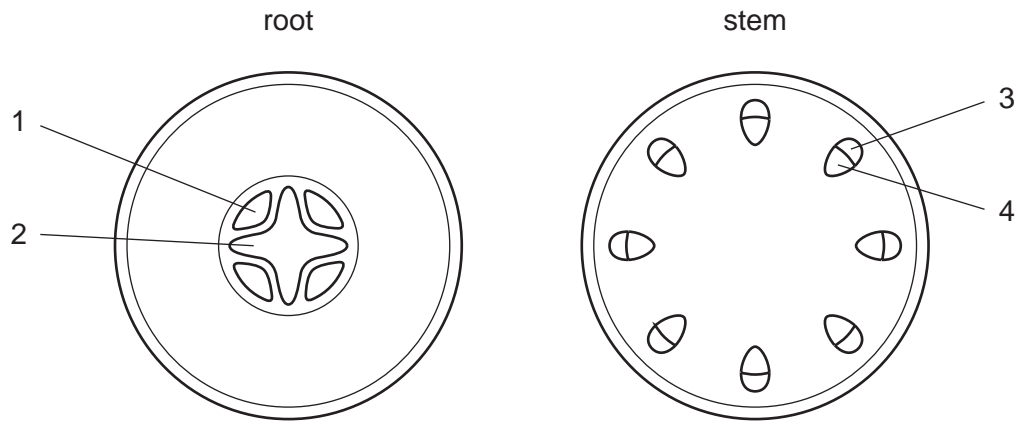

Which tissues carry amino acids in solution?

	root	stem
A	1	3
B	1	4
C	2	3
D	2	4

13 What is the correct route for blood flow in a human?

- A** left atrium → left ventricle → lungs → right ventricle → right atrium
- B** left atrium → left ventricle → right ventricle → right atrium → lungs
- C** right atrium → right ventricle → left ventricle → left atrium → lungs
- D** right atrium → right ventricle → lungs → left atrium → left ventricle

14 The diagram shows the liver and its blood supply.

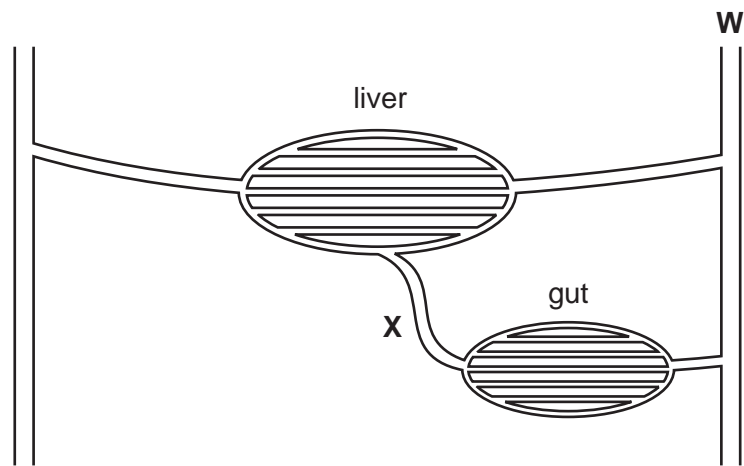

What is the name of blood vessel **X** and which substance increases in concentration between vessels **W** and **X**?

	name	substance
A	hepatic artery	carbon dioxide
B	hepatic portal vein	carbon dioxide
C	renal artery	oxygen
D	renal vein	oxygen

15 The diagram shows the investigation of blood flow in the veins of the lower arm.

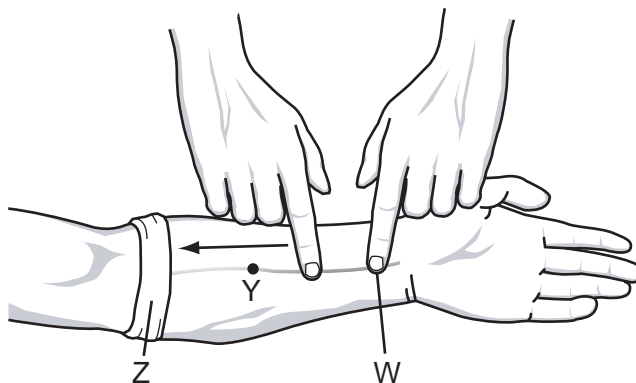

A cloth is tightly wrapped round the arm at point Z and the veins stand out clearly. One finger presses on the vein at W.

When another finger strokes the vein, as shown in the diagram, the vein lies flat between points W and Y.

Some possible explanations are listed.

- 1 The bandage at Z prevents backflow of blood.
- 2 The finger pressed at W prevents more blood entering the vein
- 3 A valve at Y prevents backflow.
- 4 A valve at Z prevents more blood from entering the vein.

Which explanations of the vein lying flat are correct?

- A** 1 and 2 **B** 1 and 4 **C** 2 and 3 **D** 2 and 4

16 After muscular exercise, which blood vessel carries the most carbon dioxide?

- A** aorta
B hepatic artery
C pulmonary vein
D vena cava

17 Which process, occurring in the human body, does **not** involve energy from respiration?

- A** contraction of heart muscle
B diffusion of oxygen from the alveoli into the blood
C digestion of bread
D maintaining a constant body temperature

18 Which changes occur as a person exercises?

	depth of breathing	breathing rate
A	decreases	decreases
B	decreases	increases
C	increases	decreases
D	increases	increases

19 Which substance has the same concentration in dialysis fluid as in blood?

- A** glucose
- B** protein
- C** salts
- D** urea

20 What happens when the core temperature of the body increases?

	diameter of surface blood vessels	urine production
A	decreases	decreases
B	decreases	increases
C	increases	decreases
D	increases	increases

21 Which diagram shows how light from a distant object is focused on the retina to form a clear image?

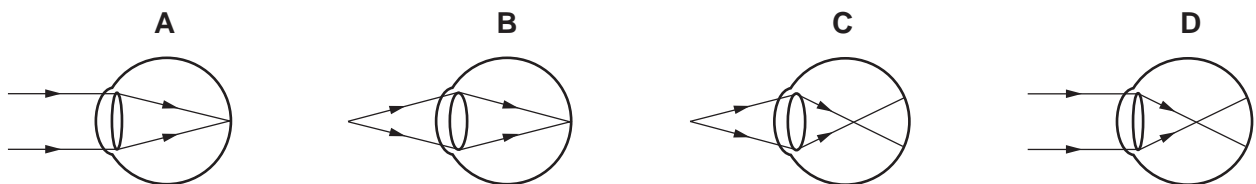

22 The diameter of a person's pupil is measured as the light intensity is varied.

During which time period does the light intensity increase fastest?

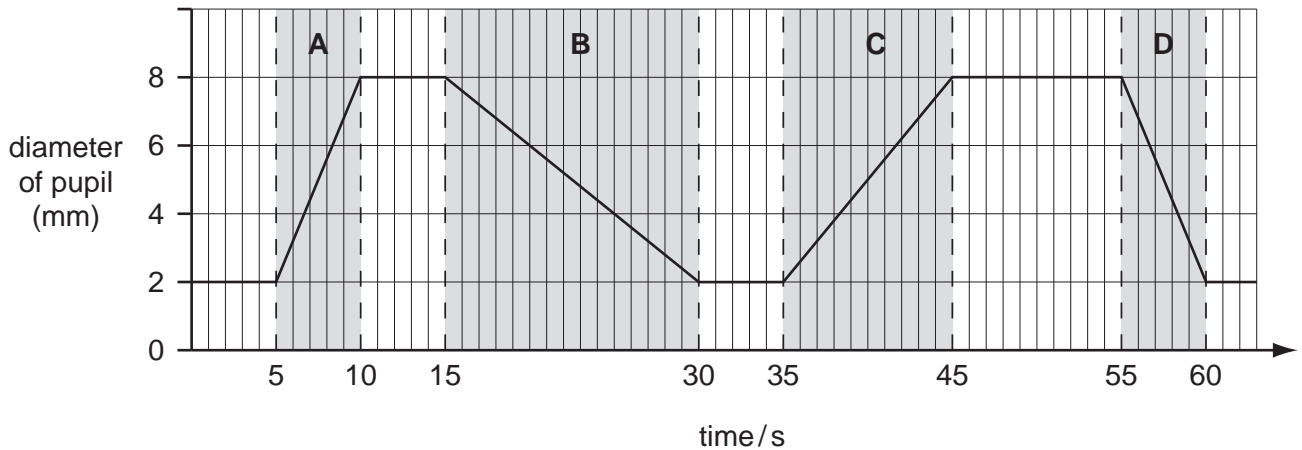

23 Which condition is treated by antibiotics?

- A diabetes
- B heroin addiction
- C malaria
- D syphilis

24 The graph shows the relationship between the average age at death and the number of cigarettes smoked per day.

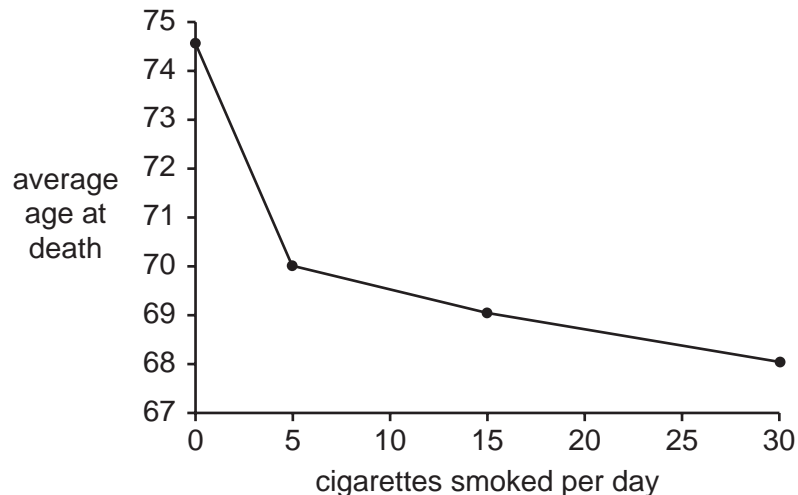

Which of the following is a correct conclusion from the graph?

- A Most people living longer than 74 years are non-smokers.
- B Most people smoking 30 cigarettes a day die from lung cancer.
- C Non-smokers live at least 4.5 years longer than people who smoke.
- D People smoking five cigarettes a day live longer than those smoking 15 cigarettes a day.

25 Which organ is damaged as it breaks down alcohol?

- A brain
- B kidney
- C liver
- D stomach

26 Yeast respire using sugar.

What conditions are needed to make which product?

	conditions	product
A	aerobic	alcohol
B	aerobic	lactic acid
C	anaerobic	alcohol
D	anaerobic	lactic acid

27 During the production of yoghurt and cheese, the pH of the mixture changes.

What causes this change in pH?

- A milk proteins becoming solid
- B the changing of lactose to lactic acid
- C the production of carbon dioxide
- D the production of ethanol

28 The diagram shows the energy flow through a food chain.

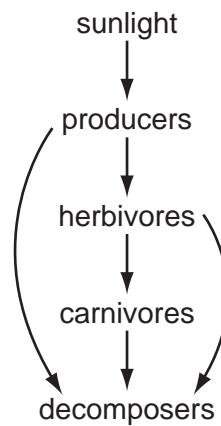

What happens to the energy that has flowed through the food chain?

- A It is lost as heat.
- B It is recycled.
- C It is stored as carbohydrate.
- D It is used to power metabolic processes.

29 A single plant provides food for many herbivores. The herbivores supply food for a few carnivores.

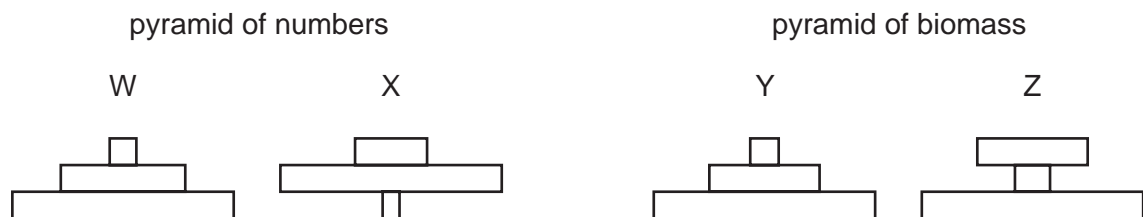

Which pyramid of numbers and which pyramid of biomass show this information?

	pyramid of numbers	pyramid of biomass
A	W	Y
B	W	Z
C	X	Y
D	X	Z

30 The diagram shows the flow of substances within an ecosystem.

The circles represent trophic levels.

Which circle represents herbivores?

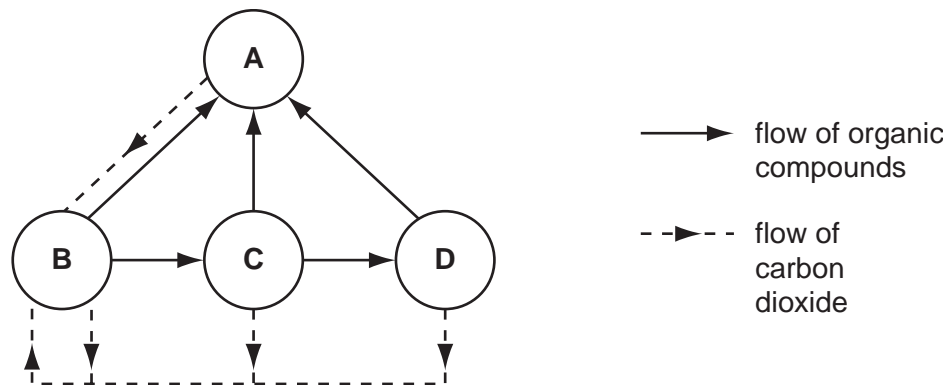

31 The single-celled organism that causes malaria is transmitted by mosquitoes.

How is a mosquito best described?

- A a disease
- B a pathogen
- C a phagocyte
- D a vector

32 Which shows a result of deforestation and the effect it has on the environment?

	result	effect
A	fewer flowering plants	reduced CO ₂ in air
B	fewer trees	increased humidity of air
C	more ground cover	wind removes soil
D	more water drains away	soil washed away

33 The diagram shows a section through a fruit containing a seed.

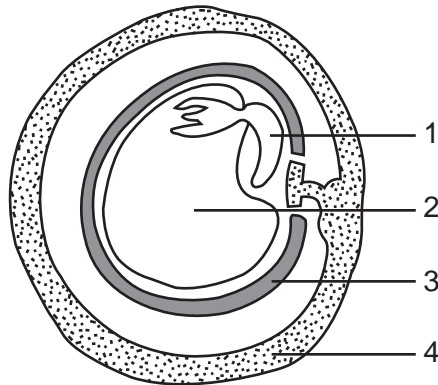

What are the labelled parts?

	1	2	3	4
A	cotyledon	radicle	pericarp	testa
B	cotyledon	radicle	testa	pericarp
C	radicle	cotyledon	pericarp	testa
D	radicle	cotyledon	testa	pericarp

34 Which statement about sexual reproduction is correct?

- A** All types of organism reproduce by this process.
- B** Many cells of one type fuse with a single cell of another type.
- C** Nuclei of two specialised cells fuse together.
- D** Parents produce genetically identical offspring.

35 The diagram shows the life cycle of a species of plant.

During which of the stages does reduction division occur?

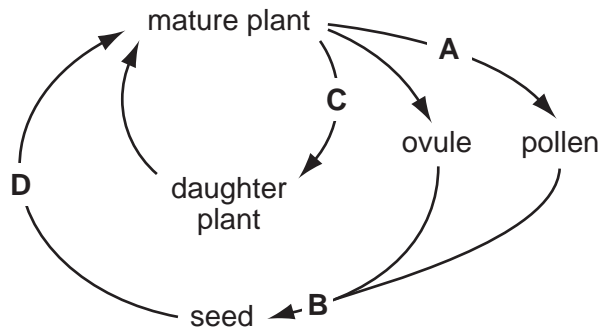

- 36 The diagram shows the arrangement of blood vessels in the uterus wall and placenta of a pregnant woman.

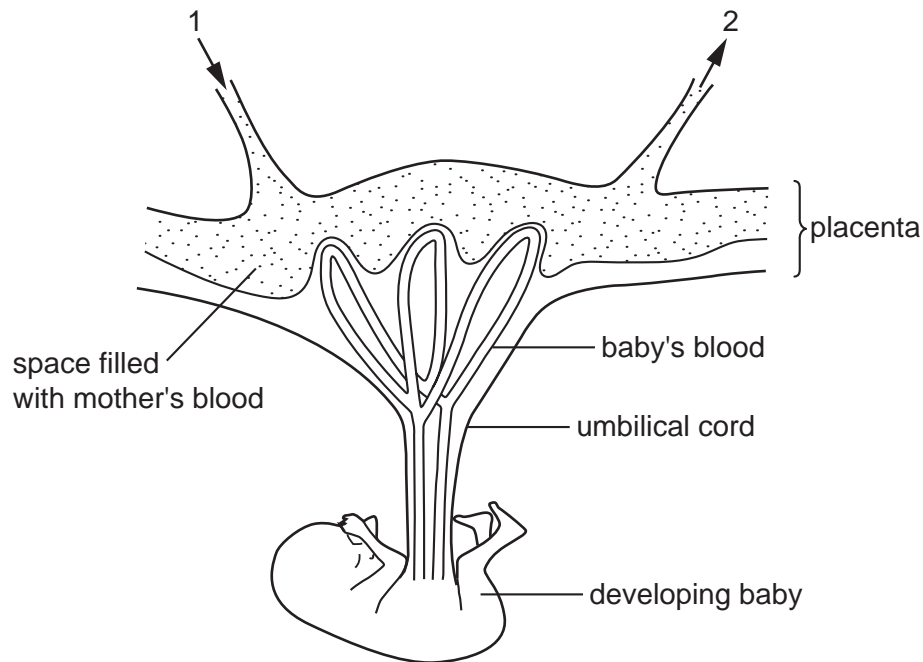

Which will increase in concentration in the blood as it flows from 1 to 2?

- A amino acids
 - B carbon dioxide
 - C glucose
 - D oxygen
- 37 Which statement describes an example of artificial selection?
- A It has been found that some strains of bacteria produce antibiotics.
 - B It is common practice to mate bulls with cows that produce the most milk.
 - C It is possible to control caterpillars on food crops by releasing small wasps which lay their eggs in caterpillars and kill them.
 - D Mosquitoes have developed strains that are resistant to insecticides.
- 38 Which process is used to produce insulin commercially?
- A extract glycogen from the liver to stimulate production of insulin
 - B extract insulin from the pancreas of human volunteers
 - C insert a bacterial gene into a person's pancreas
 - D insert the human insulin gene into a bacterium

39 The diagram shows the inheritance of coat colour in mice.

Which mouse is heterozygous for coat colour?

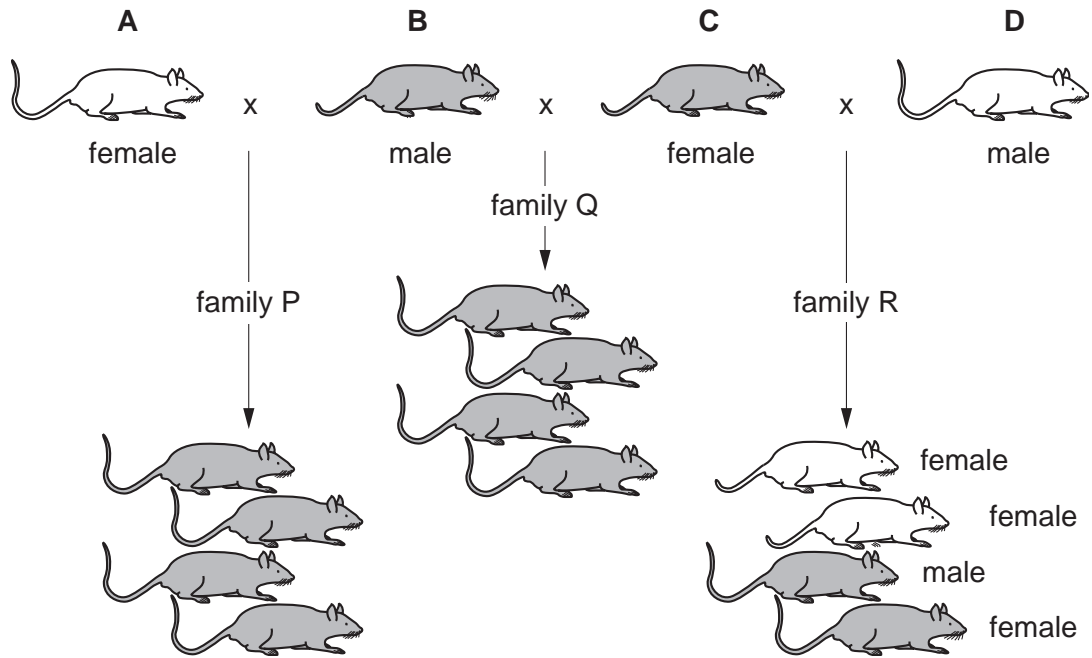

40 The diagram shows the inheritance of sex in humans.

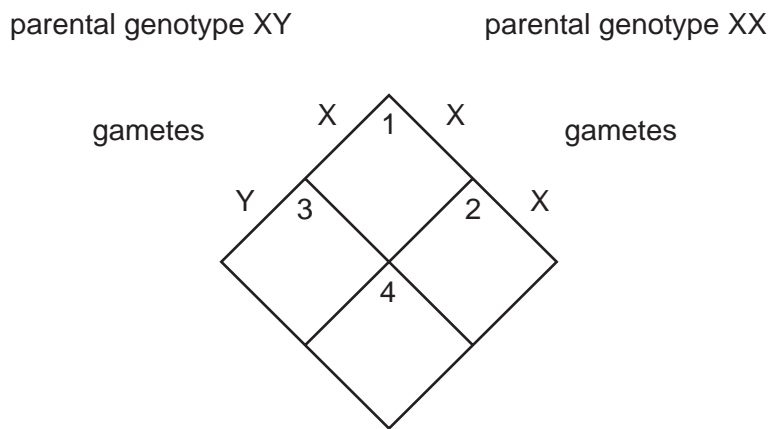

Which sex are the offspring in boxes 1, 2, 3 and 4?

	1	2	3	4
A	boy	girl	boy	girl
B	boy	girl	girl	boy
C	girl	boy	girl	boy
D	girl	girl	boy	boy

BLANK PAGE

